

Features

- 1-channel isolated barrier
- 24 V DC supply (Power Rail)
- Input for 2-wire SMART transmitters and current sources
- Signal splitter (1 input and 2 outputs)
- Dual output 0/4 mA ... 20 mA or 0/1 V ... 5 V
- Terminal blocks with test sockets
- Up to SIL 2 acc. to IEC 61508

Function

This isolated barrier is used for intrinsic safety applications. The device supplies 2-wire transmitters in the hazardous area, and can also be used with current sources. It transfers the analog input signal to the safe area as two isolated output signals. Bi-directional communication is supported for SMART transmitters that use current modulation to transmit data and voltage modulation to receive data. The output is selected as a current source, current sink, or voltage source via switches. Test sockets for the connection of HART communicators are integrated into the terminals of the device.

Application

- The device supports the following SMART protocols:
- HART
 - BRAIN
 - Foxboro
 - Honeywell DE

Assembly

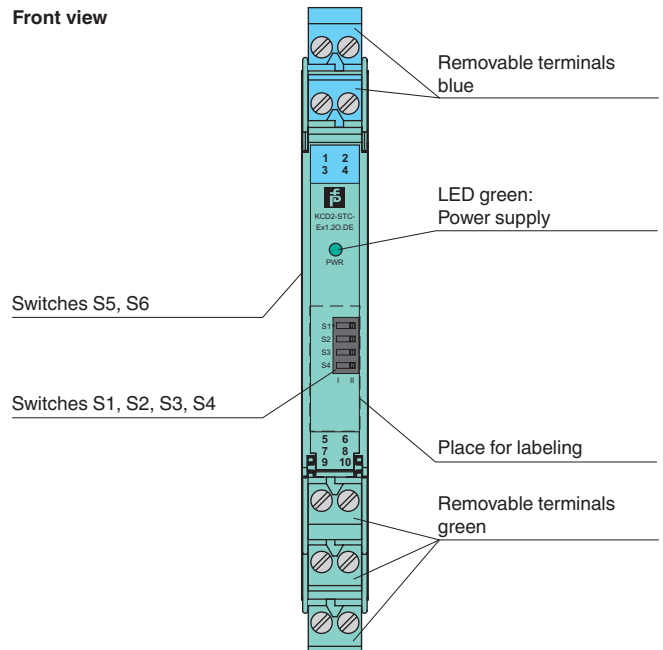

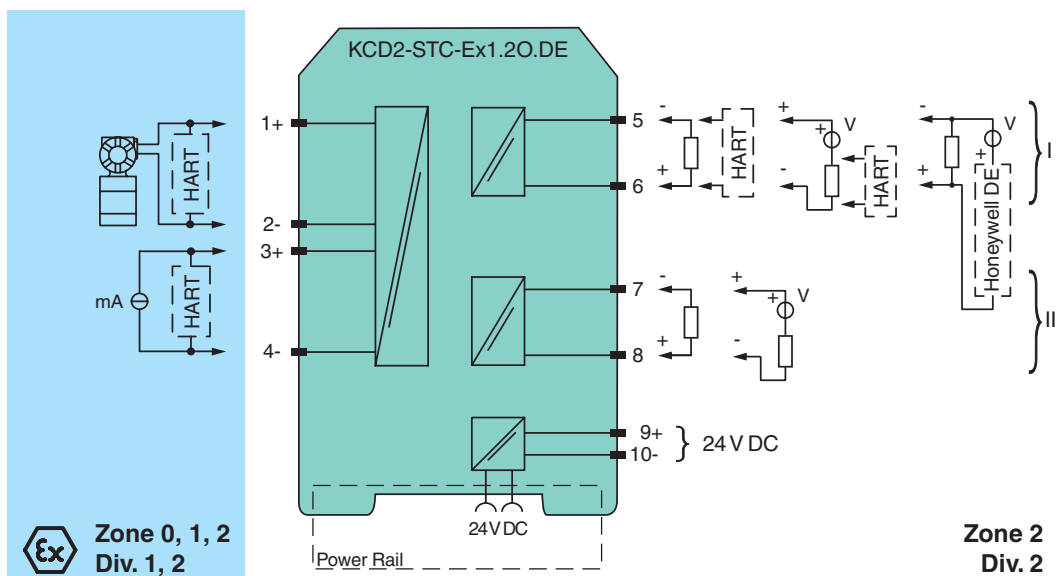

Connection



Release date 2018-03-14 16:41 Date of issue 2018-03-14 230691_eng.xml

Refer to "General Notes Relating to Pepperl+Fuchs Product Information".

General specifications	
Signal type	Analog input
Functional safety related parameters	
Safety Integrity Level (SIL)	SIL 2
Supply	
Connection	Power Rail or terminals 9+, 10-
Rated voltage U_r	18 ... 30 V DC
Ripple	within the supply tolerance
Power dissipation	approx. 1.4 W at 20 mA transfer current, 250 Ω in both outputs
Power consumption	2 W
Input	
Connection side	field side
Connection	terminals 1+, 2- (sink); 3+, 4- (source)
Input signal	0/4 ... 20 mA
Voltage drop	≤ 6.1 V at 20 mA (terminals 3, 4)
Input resistance	terminals 3+, 4-: ≤ 310 Ω terminals 1+, 2-: ≤ 500 Ω (250 Ω load)
Available voltage	terminals 1+, 2-: ≥ 16 V at 20 mA, ≥ 18.5 V at 4 mA
Output	
Connection side	control side
Connection	source: terminals 5-, 6+; 7-, 8+ sink: terminals 5+, 6-, 7+, 8-
Load	channel 1: 0 ... 500 Ω (20 mA)/ > 1 M Ω (5 V) channel 2: 0 ... 500 Ω (20 mA)/ > 1 M Ω (5 V)
Output signal	0/4 ... 20 mA or 0/1 ... 5 V
Ripple	≤ 50 μ A _{rms}
Transfer characteristics	
Deviation	$I_{out} < 20$ μ A (0.1 %); $V_{out} < 10$ mV (0.2%) incl. calibration, linearity, hysteresis and fluctuation of supply voltage, at 20 °C (68 °F), 0/4 ... 20 mA, 0/1 ... 5 V
Influence of ambient temperature	current output: 0.25 μ A/K voltage output: 80 μ V/K
Frequency range	field side into the control side: bandwidth with 0.5 V _{pp} signal 0 ... 6 kHz (-3 dB) control side into the field side: bandwidth with 0.5 V _{pp} signal 0.3 ... 6 kHz (-3 dB) [DE 1 kHz (-3 dB)]
Settling time	6 ms
Rise time/fall time	2 ms
Galvanic isolation	
Output/power supply	functional insulation, rated insulation voltage 50 V AC
Output/Output	functional insulation, rated insulation voltage 50 V AC
Indicators/settings	
Display elements	LED
Control elements	DIP-switch
Configuration	via DIP switches
Labeling	space for labeling at the front
Directive conformity	
Electromagnetic compatibility	
Directive 2014/30/EU	EN 61326-1:2013 (industrial locations)
Conformity	
Electromagnetic compatibility	NE 21:2012 EN 61326-3-2:2008
Degree of protection	IEC 60529:2001
Protection against electrical shock	UL 61010-1:2012
Ambient conditions	
Ambient temperature	-20 ... 60 °C (-4 ... 140 °F)
Mechanical specifications	
Degree of protection	IP20
Connection	screw terminals
Mass	approx. 100 g
Dimensions	12.5 x 114 x 122 mm (0.5 x 4.5 x 4.8 inch), housing type A2
Mounting	on 35 mm DIN mounting rail acc. to EN 60715:2001
Data for application in connection with hazardous areas	
EU-Type Examination Certificate	BASEEFA 13 ATEX 0077 X
Marking	 II (1)G [Ex ia Ga] IIC  II (1)D [Ex ia Da] IIIC  I (M1) [Ex ia Ma] I
Input	[Ex ia Ga] IIC, [Ex ia Da] IIIC, [Ex ia Ma] I

Release date 2018-03-14 16:41 Date of issue 2018-03-14 230691_eng.xml

Refer to "General Notes Relating to Pepperl+Fuchs Product Information".

Supply		
Maximum safe voltage	U_m	250 V (Attention! The rated voltage can be lower.)
Equipment		
terminals 1+, 2-		
Voltage	U_o	25.2 V
Voltage	U_q	28.2 V
Current	I_o	93 mA
Power	P_o	656 mW
Equipment		
terminals 3+, 4-		
Voltage	U_i	30 V
Current	I_i	115 mA
Power	P_i	700 mW
Voltage	U_o	5 V
Current	I_o	6.8 mA
Power	P_o	1.6 mW
Output		
Maximum safe voltage	U_m	250 V (Attention! The rated voltage can be lower.)
Certificate		
BASEEFA 13 ATEX 0078 X		
Marking		
⊕ II 3G Ex nA II T4 Gc [device in zone 2]		
Galvanic isolation		
Input/Output		
safe electrical isolation acc. to IEC/EN 60079-11, voltage peak value 375 V		
Input/power supply		
safe electrical isolation acc. to IEC/EN 60079-11, voltage peak value 375 V		
Directive conformity		
Directive 2014/34/EU		
EN 60079-0:2012+A11:2013 , EN 60079-11:2012 , EN 60079-15:2010		
International approvals		
UL approval		
Control drawing		
116-0380 (cULus)		
IECEX approval		
IECEX BAS 13.0043X		
Approved for		
[Ex ia Ga] IIC, [Ex ia Da] IIIC, [Ex ia Ma] I		
General information		
Note		
Both output loads must be connected to ensure complete and correct operation within the technical specification.		
Supplementary information		
Observe the certificates, declarations of conformity, instruction manuals, and manuals where applicable. For information see www.pepperl-fuchs.com .		

Release date 2018-03-14 16:41 Date of issue 2018-03-14 230691_eng.xml

Configuration

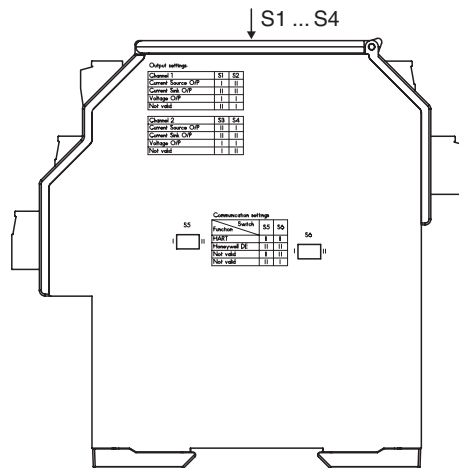

Output switch settings

Channel 1	S1	S2
Current source output	I	II
Current sink output	II	II
Voltage output	I	I
Not valid	II	I

Communication switch settings

Function	S5	S6
HART transparency	I	I
Honeywell DE transparency	II	II
Not valid	I	II
Not valid	II	I

Channel 2	S3	S4
Current source output	II	I
Current sink output	II	II
Voltage output	I	I
Not valid	I	II

Factory settings: current source output, for both channels with HART transparency.

Accessories

Power feed module KFD2-EB2

The power feed module is used to supply the devices with 24 V DC via the Power Rail. The fuse-protected power feed module can supply up to 150 individual devices depending on the power consumption of the devices. Collective error messages received from the Power Rail activate a galvanically-isolated mechanical contact.

Power Rail UPR-03

The Power Rail UPR-03 is a complete unit consisting of the electrical insert and an aluminium profile rail 35 mm x 15 mm. To make electrical contact, the devices are simply engaged.

Profile Rail K-DUCT with Power Rail

The profile rail K-DUCT is an aluminum profile rail with Power Rail insert and two integral cable ducts for system and field cables. Due to this assembly no additional cable guides are necessary.



Power Rail and Profile Rail must not be fed via the device terminals of the individual devices!

Release date 2018-03-14 16:41 Date of issue 2018-03-14 230691_eng.xml