



Model Number

PMI80-F90-C2EP-IO-V15-3G-3D

Features

- Parameterization and diagnosis via IO-Link
- Measuring range 0 ... 80 mm
- Parameterisable measuring range
- Analog current or voltage output, programmable
- 2 Push-pull outputs
- Switch points programmable via IO-Link

Application

Attention!

If the sensor is supplied via an IO-Link-Master, ensure that the sum of the no-load supply current and operating currents of all sensor outputs does not exceed the maximum current the IO-Link-Master can supply.

Accessories

BT-F90-W

Damping element for sensors of type F90, F112, and F166; side hole

MH-F90

Mounting bracket for mounting of F90 sensors

V15-G-2M-PVC

Female cordset, M12, 5-pin, PVC cable

V15-W-2M-PVC

Female cordset, M12, 5-pin, PVC cable

Technical Data

General specifications

Switching element function	Analog current or voltage output, programmable
Object distance	2 switch outputs, programmable
Measurement range	0.5 ... 3 mm, recommended: 1.5 mm
Linearity range	0 ... 80 mm
	1 ... 79 mm

Nominal ratings

Operating voltage	U_B	12 ... 30 V DC (13 ... 30 V when analog voltage output is parameterized)
Reverse polarity protection		reverse polarity protected
Linearity error		within measuring range: ± 0.8 mm within linearity range: ± 0.4 mm
Repeat accuracy	R	± 0.1 mm
Resolution		50 μ m
Temperature drift		± 0.5 mm (-25 °C ... 70 °C)
No-load supply current	I_0	≤ 40 mA
Operating voltage indicator		LED green

Functional safety related parameters

MTTF _d	318 a
Mission Time (T _M)	20 a
Diagnostic Coverage (DC)	0 %

Indicators/operating means

LED S1	switching state Switching output 1
LED S2	switching state Switching output 2
LED S3	Damping element in the configured analog measuring range
LED STATUS	Status display LED, green/red (Power on, communication/error, missing damping element)

Interface

Interface type	IO-Link (via C/Q = Pin 4)
Device profile	Smart Sensor
Transfer rate	COM 2 (38.4 kBaud)
Value range	0000h ... 6400h
IO-Link Revision	1.1
Min. cycle time	2.3 ms
Process data width	Process data input: 16 Bit Process data output: none
SIO mode support	yes
Device ID	0x200304 (2097924)
Compatible master port type	A

Switching output

Output type	2 push-pull outputs (can be parameterized), short-circuit-proof, reverse polarity protection, surge-proof
Operating current	I_L ≤ 100 mA / output
Switching window	± 1 mm
Switching hysteresis	0.2 mm
Voltage drop	≤ 3 V
Short-circuit protection	pulsing

Analog output

Output type	1 current output: 4 ... 20 mA or 1 voltage output: 0 ... 10 V, programmable
Load resistor	current output: ≤ 400 Ω voltage output: ≥ 1000 Ω
Short-circuit protection	voltage output: current limit

Ambient conditions

Ambient temperature	-25 ... 85 °C (-13 ... 185 °F)
---------------------	--------------------------------

Mechanical specifications

Connection type	5-pin, M12 x 1 connector
Degree of protection	IP67 / IP69K
Material	
Housing	PBT, stainless steel 1.4571, brass, nickel-plated
Target	mild steel, e. g. 1.0037, SR235JR (formerly St37-2)
Mass	83 g

General information

Use in the hazardous area	see instruction manuals
---------------------------	-------------------------

Compliance with standards and directives

Standard conformity	
Standards	EN 60947-5-2:2007 EN 60947-5-2/A1:2012 IEC 60947-5-2:2007 IEC 60947-5-2 AMD 1:2012 EN 60947-5-7:2003 EN61131-9:2013 IEC 60947-5-7:2003 IEC 61131-9:2013

Approvals and certificates

UL approval	cULus Listed, Class 2 Power Source, Type 1 enclosure
-------------	--

Dimensions

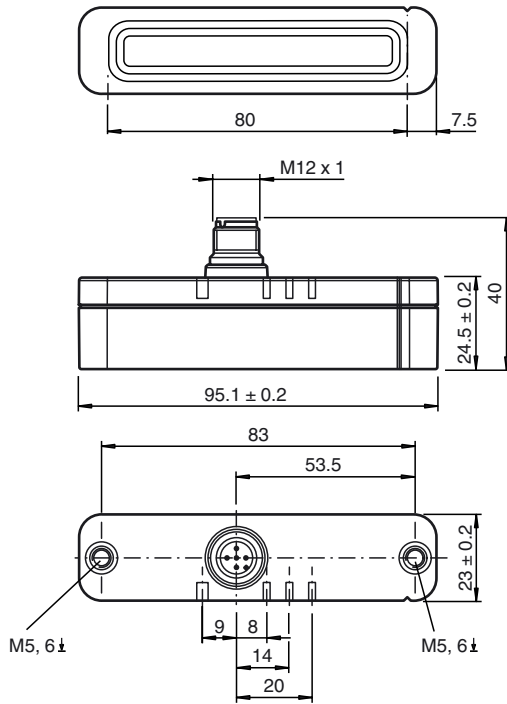

Electrical Connection

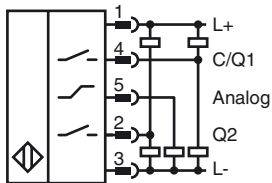

Pinout

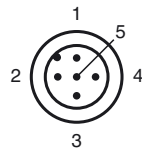

Wire colors in accordance with EN 60947-5-2

1	BN	(brown)
2	WH	(white)
3	BU	(blue)
4	BK	(black)
5	GY	(gray)

Additional Information

dimensions for the target object:

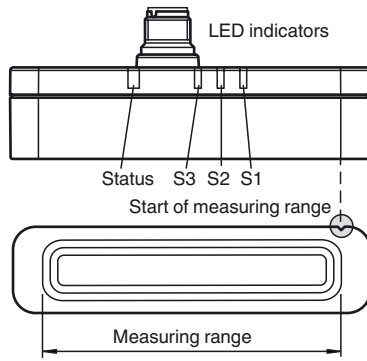
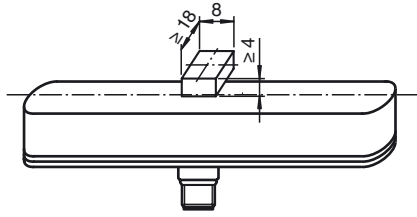

Release date: 2017-10-04 14:16 Date of issue: 2017-10-04 231930_eng.xml

Refer to "General Notes Relating to Pepperl+Fuchs Product Information".

Pepperl+Fuchs Group
www.pepperl-fuchs.com

USA: +1 330 486 0001
fa-info@us.pepperl-fuchs.com

Germany: +49 621 776 4411
fa-info@de.pepperl-fuchs.com

Singapore: +65 6779 9091
fa-info@sg.pepperl-fuchs.com

Data for application in connection with hazardous areas

Equipment protection level	Gc (nA) , Dc
Equipment protection level Gc (nA)	
Type of protection	"n"
CE marking	CE
Certificates	
ATEX certificate	PF 15 CERT 3754 X
ATEX marking	Ex II 3G Ex nA IIC T6 Gc
Standards	EN 60079-0:2012+A11:2013 , EN 60079-15:2010
Possible characteristics	maximum operating voltage U_{Bmax} , maximum load current I_{Lmax} , minimum series resistance R_V , maximum analog output voltage U_{Amax} , maximum analog output current I_{Amax}
Maximum permissible ambient temperature T_{amb}	Also observe the maximum permissible ambient temperature stated in the general technical data. Keep to the lower of the two values. mode of operation 1 at $U_{Bmax} = 30$ V and maximum 2 switching outputs with each $I_{Lmax} = 100$ mA and 1 analog output with $I_{Amax} = 20$ mA or $U_{Amax} = 10$ V : 35 °C (95 °F) mode of operation 2 at $U_{Bmax} = 30$ V and maximum 1 switching output with $I_{Lmax} = 100$ mA : 50 °C (122 °F)
Equipment protection level Dc	
Type of protection	Protection by enclosure "tc"
CE marking	CE
Certificates	
ATEX certificate	PF 15 CERT 3774 X
ATEX marking	Ex II 3D Ex tc IIIC T80°C Dc
Standards	EN 60079-0:2012/A11+2013 , EN 60079-31:2014
Possible characteristics	maximum operating voltage U_{Bmax} , maximum load current I_{Lmax} , minimum series resistance R_V , maximum analog output voltage U_{Amax} , maximum analog output current I_{Amax}
Maximum permissible ambient temperature T_{amb}	Also observe the maximum permissible ambient temperature stated in the general technical data. Keep to the lower of the two values. mode of operation 1 at $U_{Bmax} = 30$ V and maximum 2 switching outputs with each $I_{Lmax} = 100$ mA and 1 analog output with $I_{Amax} = 20$ mA or $U_{Amax} = 10$ V : 35 °C (95 °F) mode of operation 2 at $U_{Bmax} = 30$ V and maximum 1 switching output with $I_{Lmax} = 100$ mA : 50 °C (122 °F)

Release date: 2017-10-04 14:16 Date of issue: 2017-10-04 231930_eng.xml