

Incremental rotary encoder

RSI58O-02YAAR61T-01024

- Resistant to salt water
- Industrial standard housing Ø58 mm
- 1024 ppr
- Recessed hollow shaft
- 10 V ... 30 V with short-circuit proof push-pull output



Function

This hollow shaft encoder was specially developed for use in regions heavily influenced by maritime conditions or for offshore use. The sea-waterproof coated housing and the stainless steel shaft are perfectly suited for these tough environmental influences. The internal electronics also meet these high requirements. The durable code disc ensures that the encoder can be used for applications exposed to extreme shock and vibration loads.

Dimensions

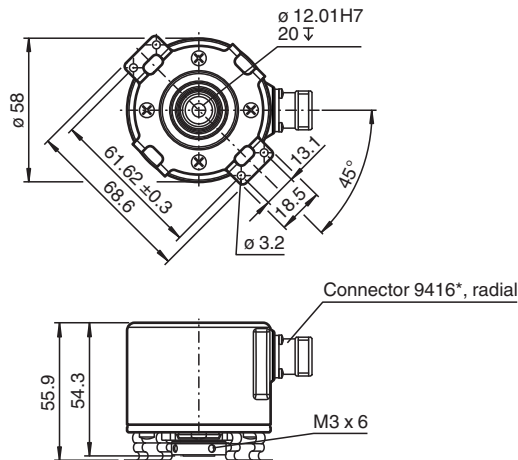

Technical Data

General specifications

Detection type	photoelectric sampling
Pulse count	1024

Functional safety related parameters

MTTF _d	140 a
Mission Time (T _M)	20 a
L _{10h}	2 E+9
Diagnostic Coverage (DC)	0 %

Electrical specifications

Operating voltage	U _B	10 ... 30 V DC
No-load supply current	I ₀	max. 60 mA

Output

Release date: 2022-12-12 Date of issue: 2022-12-12 Filename: 248673_eng.pdf

Refer to "General Notes Relating to Pepperl+Fuchs Product Information".

Pepperl+Fuchs Group
www.pepperl-fuchs.com

USA: +1 330 486 0001
fa-info@us.pepperl-fuchs.com

Germany: +49 621 776 1111
fa-info@de.pepperl-fuchs.com

Singapore: +65 6779 9091
fa-info@sg.pepperl-fuchs.com

PF PEPPERL+FUCHS

Technical Data

Output type		push-pull, incremental
Voltage drop	U_d	< 4.4 V
Load current		max. per channel 40 mA , short-circuit prtected (not with U_b), reverse polarity protected
Output frequency		max. 200 kHz
Rise time		400 ns
Connection		
Connector		type 9416 (M23), 12-pin
Standard conformity		
Degree of protection		DIN EN 60529, IP65, IP66, IP68
Climatic testing		
Static climatic testing		DIN EN 60068-2-78 , no moisture condensation
Cyclic climatic testing		DIN EN 60068-2-30 55 °C, 6 cycles
Salt spray test		DIN EN 60068-2-52 , 672 h
Emitted interference		EN 61000-6-4:2007/A1:2011
Noise immunity		EN 61000-6-2:2005
Shock resistance		DIN EN 60068-2-27, 100 g, 3 ms
Vibration resistance		DIN EN 60068-2-6, 10 g, 10 ... 2000 Hz
Approvals and certificates		
UL approval		cULus Listed, General Purpose, Class 2 Power Source
Ambient conditions		
Operating temperature		-40 ... 60 °C (-40 ... 140 °F)
Storage temperature		-40 ... 70 °C (-40 ... 158 °F)
Mechanical specifications		
Material		
Housing		aluminum, coated, salt water resistant
Flange		aluminum, coated, salt water resistant
Shaft		stainless steel 1.4404 / AISI 316L
Mass		approx. 280 g
Rotational speed		max. 100 min ⁻¹
Moment of inertia		≤ 35 gcm ²
Starting torque		≤ 4.5 Ncm
Shaft load		
Angle offset		1 °
Axial offset		max. 1 mm

Connection

Signal	Connector 9416, 12-pin
GND	10
U _b	12
A	5
B	8
\bar{A}	6
\bar{B}	1
0	3
$\bar{0}$	4
n.c.	2
n.c.	7
Screen	Housing
n.c.	9
n.c.	11

Operation

Signal outputs

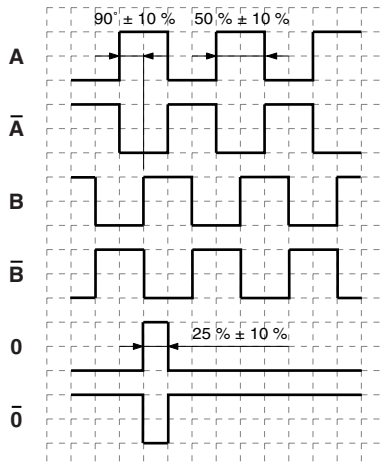

↺ cw - with view onto the shaft clamping ring

Type Code

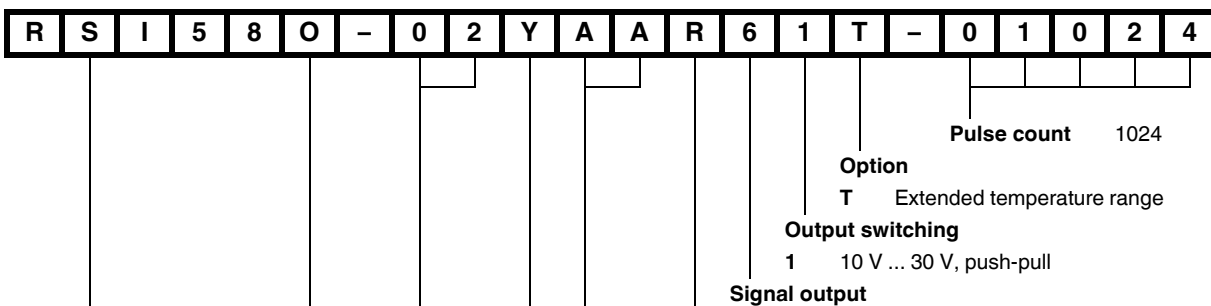

Release date: 2022-12-12 Date of issue: 2022-12-12 Filename: 248673_eng.pdf

Refer to "General Notes Relating to Pepperl+Fuchs Product Information".

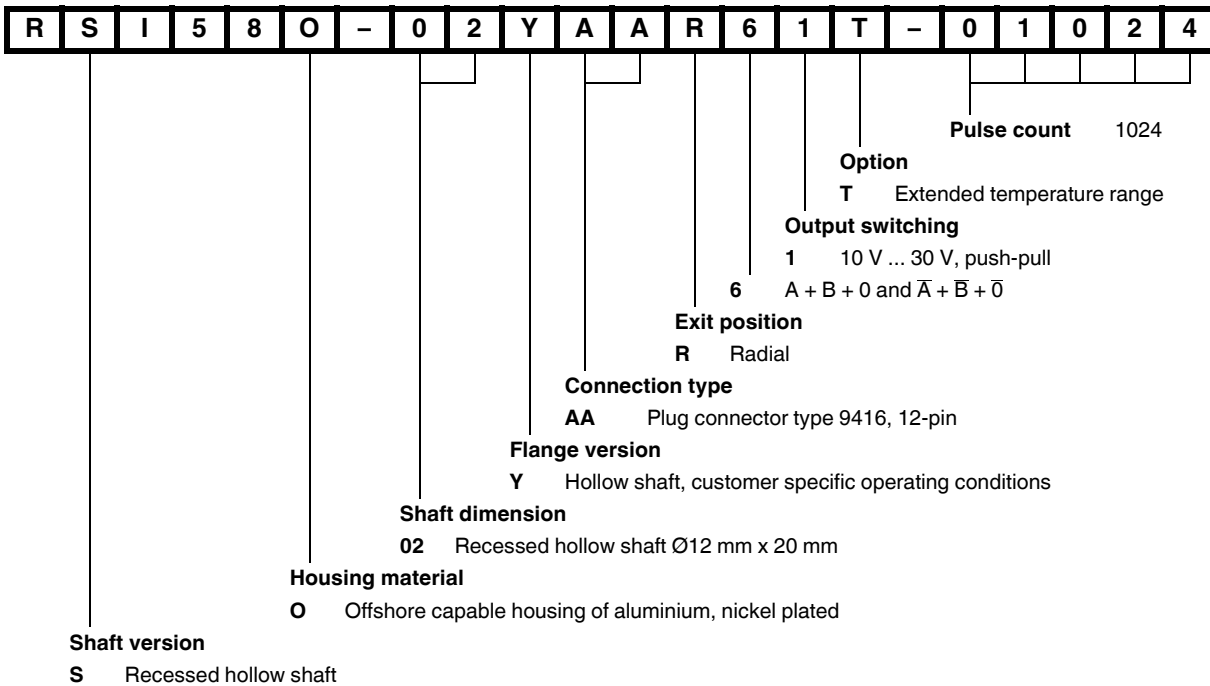

Additional Information

Anti-interference measures

The use of highly sophisticated microelectronics requires a consistently implemented anti-interference and wiring concept. This becomes all the more important the more compact the constructions are and the higher the demands are on the performance of modern machines.

The following installation instructions and proposals apply for "normal industrial environments". There is no ideal solution for all interfering environments.

When the following measures are applied, the encoder should be in perfect working order:

- With RS 422 Interface devices and long cables, a line-termination by a suitable termination resistor is required.
- A shielded cable should be used at installation. For the connection of RS 422 devices the wires must be twisted in pairs.
- The wiring of the encoder should be laid at a large distance to energy lines which could cause interferences.
- Cable cross-section of the screen at least 4 mm².
- Cable cross-section at least 0,14 mm².
- The wiring of the screen and 0 V should be arranged radially, if and when possible.
- Do not kink or jam the cables.
- Adhere to the minimum bending radius of 10 mm and avoid tensile as well as shearing load.

Operating instructions

Every encoder manufactured by Pepperl+Fuchs leaves the factory in a perfect condition. In order to ensure this quality as well as a faultless operation, the following specifications have to be taken into consideration:

- Avoid any impact on the housing and in particular on the encoder shaft as well as the axial and radial overload of the encoder shaft.
- The accuracy and service life of the encoder is guaranteed only, if a suitable coupling and / or torque support is used.
- Any wiring work has to be carried out with the system in a dead condition.
- The maximum operating voltages and output currents must not be exceeded. The devices have to be operated at extra-low safety voltage.
- Sensor wires are connected internally to the supply voltage and may be used for Voltage adjustment or -control in case of long cables.
- Unused sensor wires should either isolated or connected to the corresponding supply potentials (GND Sens connected to GND and Ub Sens connected to UB).
- Unused outputs must be isolated before initial use of the encoder.

Notes on connecting the electric screening

The immunity to interference of a plant depends on the correct screening. In this field installation faults occur frequently. Often the screen is applied to one side only, and is then soldered to the earthing terminal with a wire, which is a valid procedure in LF engineering. However, in case of EMC the rules of HF engineering apply.

One basic goal in HF engineering is to pass the HF energy to earth at an impedance as low as possible as otherwise energy would discharge into the cable. A low impedance is achieved by a large-surface connection to metal surfaces.

The following instructions have to be observed:

- Apply the screen on both sides to a "common earth" in a large surface, if there is no risk of equipotential currents.

- The screen has to be passed behind the insulation and has to be clamped on a large surface below the tension relief.
- In case of cable connections to screw-type terminals, the tension relief has to be connected to an earthed surface.
- If plugs are used, metallised plugs only should be fitted (such as sub D plugs with metallised housing). Please observe the direct connection of the tension relief to the housing.

Advantage: metalised connector,
shield
relief
clamped with the strain
clamp

Disadvantage: soldering shield on

