

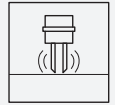

Vibration Limit Switch

LVL-A7



- Limit switch for liquids
- Onsite function check possible thanks to LED indication
- Large selection of process connections for hassle-free installation in existing systems
- Easy to install even at points difficult to access due to compact design
- Rugged stainless steel housing
- Cost-saving plug connections
- Approval as overflow protection and leak detection system acc. to WHG



Function

The Vibracon LVL-A7 is a limit switch for liquids and is used in tanks, vessels and pipes. The device is used for overflow prevention or pump protection in cleaning and filter systems as well as in cooling and lubrication vessels, for instance. The device is suitable for applications in which float switches or conductive, capacitance and optical sensors have been used up to now. The device also works in areas where these measuring principles are not suitable due to conductivity, buildup, turbulence, flow conditions or air bubbles.

The device can be used for process temperatures up to:

- 100 °C (212 °F)
- 150 °C (302 °F)

The device is not suitable for use in hazardous areas.

For hygienic areas we recommend the use of Vibracon LVL A7H.

Connection

Example: electrical connection with M12 plug

Further electrical connections see technical information (TI).

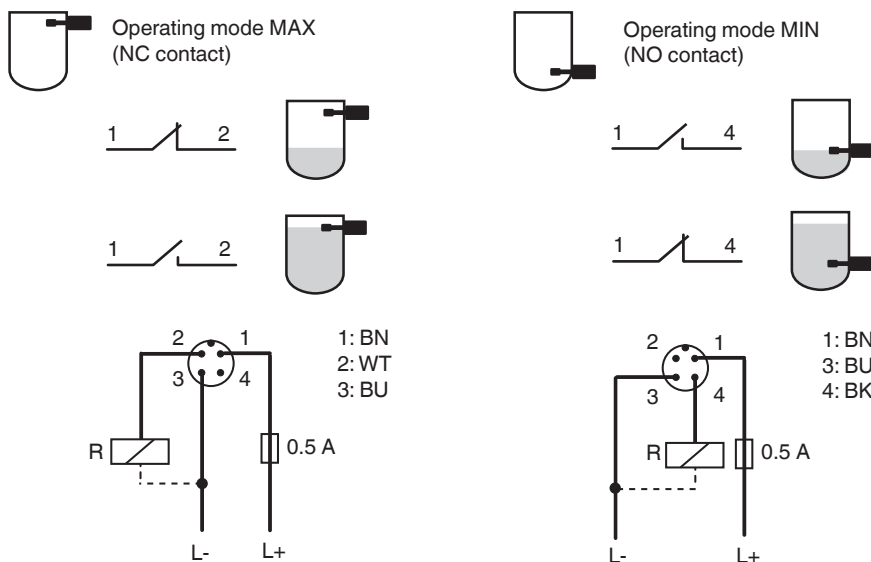

Release date: 2023-09-11 Date of issue: 2023-09-11 Filename: 275573_eng.pdf

Technical Data

General specifications

Refer to "General Notes Relating to Pepperl+Fuchs Product Information".

Pepperl+Fuchs Group
www.pepperl-fuchs.com

USA: +1 330 486 0002
pa-info@us.pepperl-fuchs.com

Germany: +49 621 776 2222
pa-info@de.pepperl-fuchs.com

Singapore: +65 6779 9091
pa-info@sg.pepperl-fuchs.com

PF PEPPERL+FUCHS

Technical Data

Measuring method	The tuning fork is brought to its resonance frequency by means of a piezoelectric drive. If the tuning fork is covered by liquid, this frequency changes. The electronics monitor the resonance frequency and indicate whether the tuning fork is freely vibrating or is covered by liquid.	
Construction type		compact device device with short tube
Operating mode	MAX = maximum safety: The device keeps the electronic switch closed as long as the liquid level is below the fork. example application: overspill protection MIN = minimum safety: The device keeps the electronic switch closed as long as the fork is immersed in liquid. example application: dry running protection of pumps The electronic switch opens if the limit is reached, if a fault occurs or in the event of a power fails (quiescent current principle)	
Series		Vibracon LVL-A7
Supply		
Rated voltage	U _r	- DC-PNP: 10 ... 35 V DC, 3-wire - AC/DC: 20 ... 253 V AC/DC, 2-wire
Current consumption		- DC-PNP: < 15 mA - AC/DC: < 3.8 mA
Power consumption		- DC-PNP: < 975 mW - AC/DC: < 850 mW
Input		
Measured variable		density
Measurement range		min. 0.7 g/cm ³ , optional > 0.5 g/cm ³
Output		
Output type		switching output
Switching current		max. 250 mA
Directive conformity		
Electromagnetic compatibility		
Directive 2014/30/EU		EN 61326-1:2006 , EN 61326-2-3:2006
Low voltage		
Directive 2014/35/EU		EN 61010-1:2010
Conformity		
Electromagnetic compatibility		NE 21
Degree of protection		IEC 60529
Shock resistance		EN 60068-2-27
Vibration resistance		EN 60068-2-64
Climate class		DIN EN 60068-2-38/IEC 68-2-38
Measurement accuracy		
Reference operating conditions		- ambient temperature: 25 °C (+77 °F) - process pressure: 1 bar (14.5 psi) - fluid: water (density: approx. 1 g/cm ³ , viscosity: 1 mm ² /s) - medium temperature: 25 °C (+77 °F) - density setting: > 0.7 g/cm ³ - switching time delay: standard (0,5 s, 1 s)
Measured value resolution		< 0.5 mm
Measuring frequency		approx. 1100 Hz in air
Switching point		13 mm ± 1 mm
Non-repeatability		± 1 mm acc. to DIN 61298-2
Hysteresis		max. 3 mm
Influence of ambient temperature		negligible
Influence of medium temperature		-25 µm/°C
Influence of medium pressure		-20 µm/bar
Switching time		- 0.5 s when tuning fork is covered - 1.0 s when tuning fork is uncovered - other switching times on request
Operating conditions		
Installation conditions		
Installation position		see section mounting position

Release date: 2023-09-11 Date of issue: 2023-09-11 Filename: 275573_eng.pdf

Refer to "General Notes Relating to Pepperl+Fuchs Product Information".

Pepperl+Fuchs Group
www.pepperl-fuchs.comUSA: +1 330 486 0002
pa-info@us.pepperl-fuchs.comGermany: +49 621 776 2222
pa-info@de.pepperl-fuchs.comSingapore: +65 6779 9091
pa-info@sg.pepperl-fuchs.com

PEPPERL+FUCHS

Technical Data

Ambient conditions	
Ambient temperature	-40 ... 70 °C (-40 ... 158 °F)
Storage temperature	-40 ... 85 °C (-40 ... 185 °F)
Shock resistance	a = 300 m/s ² = 30 g, 3 planes x 2 directions x 3 shocks x 18 ms, as per test Ea
Vibration resistance	a(RMS) = 50 m/s ² , ASD = 1.25 (m/s ²) ² /Hz, f = 5 to 2000 Hz, t = 3 x 2 h
Process conditions	
Process temperature	-40 ... +100 °C (-40 ... +212 °F) -40 ... +150 °C (-40 ... +302 °F)
Process pressure (static pressure)	-1 ... +40 bar (-14.5 ... +580 psi)
State of aggregation	liquid
Density	min. 0.7 g/cm ³ , optional > 0.5 g/cm ³
Viscosity	1 ... 10000 mPa/s, dynamic viscosity
Solid contents	< Ø5 mm
Mechanical specifications	
Degree of protection	- IP65/67, NEMA 4X enclosure (plug M12) - IP65, NEMA 4X enclosure (valve plug) - IP65/68, NEMA 4X/6P enclosure (cable)
Connection	- cable 5 m - valve plug NPT1/2 - valve plug QUICKON - valve plug M16 - plug M12
Material	see technical information (TI)
Surface quality	R _a < 3.2 µm
Mass	see technical information (TI)
Dimensions	see technical information (TI)
Process connection	- thread ISO 228 G1/2, G3/4, G1 - thread EN 10226 R1/2, R3/4, R1 - thread ASME MNPT1/2, MNPT3/4, MNPT1
Indication and operation	
Display elements	The LED display is on the connection side. - green LED: indication of ready to operate - red LED: fault indication - yellow LED: operating mode indication
Function test	function test with test magnet (optional accessory)
Certificates and approvals	
Overspill protection	Z-65.11-554 (overspill protection acc. to WHG) Z-65.40-555 (leak detection system acc. to WHG) If you need the approvals also in paper form, select the option WH in the type code.
General information	
Supplementary documentation	technical information (TI) manual (BA) approval (ZE)
Supplementary information	Statement of Conformity, Declaration of Conformity, Attestation of Conformity and instructions have to be observed where applicable. For information see www.pepperl-fuchs.com .
Accessories	
Designation	see technical information (TI)

Assembly

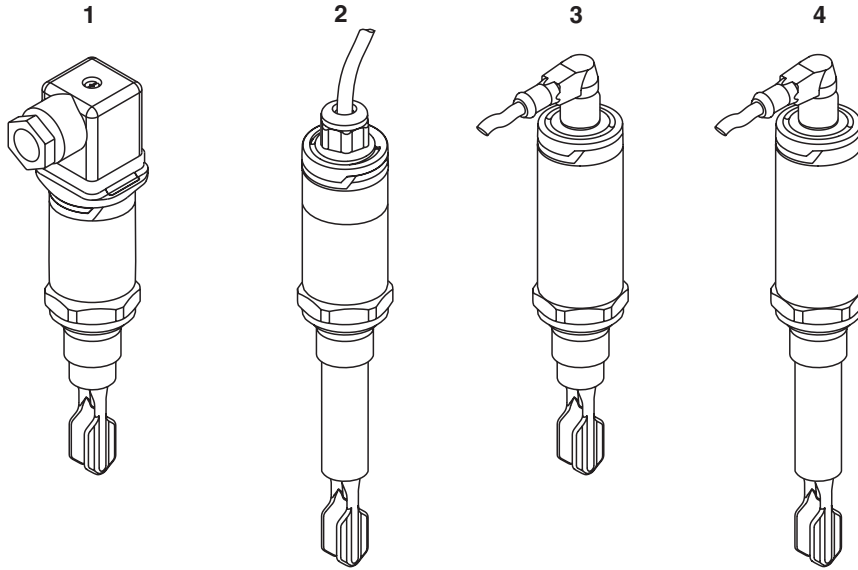

- 1 Compact version with valve plug
- 2 Short tube version with cable
- 3 Compact version with M12 plug
- 4 Short tube version with M12 plug

Further device versions see technical information (TI).

Type Code

This overview does not mark options which are mutually exclusive.
Option with ** = multiple options can be selected

L	V	L	-	A	7	-	(1)	(2)	(3)	-	(4)	(5)	-	(6)
---	---	---	---	---	---	---	-----	-----	-----	---	-----	-----	---	-----

LVL-A7	Device
LVL-A7	Limit switch for liquids

(1)	Process temperature
A	max. 100 °C (212 °F)
B	max. 150 °C (302 °F)

(2)	Process connection
Threads	
G1	G1/2, ISO 228, 316L
G2	G3/4, ISO 228, 316L, for installation in weld-in adapter (accessory)
G3	G1, ISO 228, 316L, fork length 66.4 mm (compact version) or 103.3 mm (short tube version)
G4	G1, ISO 228, 316L, fork length 77.4 mm (compact version) or 116.8 mm (short tube version), for installation in weld-in adapter (accessory)
G5	G3/4, ISO 228, 316L
N1	MNPT1/2, ASME, 316L
N2	MNPT3/4, ASME, 316L
N3	MNPT1, ASME, 316L
R1	R1/2, EN 10226, 316L
R2	R3/4, EN 10226, 316L
R3	R1, EN 10226, 316L
XX	Special version

(3)	Sensor type
A	Compact version, $R_a < 3.2 \mu\text{m}$, 316L
B	Short tube version, $R_a < 3.2 \mu\text{m}$, 316L
X	Special version

(4)	Electrical output
E5	3-wire, 10 to 35 V DC, PNP
WA	2-wire, 19 to 253 V AC/DC

(5)	Electrical connection
PC	Cable 5 m, IP65/68, NEMA 4X/6P

Release date: 2023-09-11 Date of issue: 2023-09-11 Filename: 275573_eng.pdf

Refer to "General Notes Relating to Pepperl+Fuchs Product Information".

Pepperl+Fuchs Group
www.pepperl-fuchs.com

USA: +1 330 486 0002
pa-info@us.pepperl-fuchs.com

Germany: +49 621 776 2222
pa-info@de.pepperl-fuchs.com

Singapore: +65 6779 9091
pa-info@sg.pepperl-fuchs.com

Type Code

(5) Electrical connection	
PN	Valve connector NPT1/2, ISO 4400, IP65, NEMA 4X
PS	Valve connector QUICKON, IP65, NEMA 4X
PU	Valve connector M16, ISO 4400, IP65, NEMA 4X
V1	Connector M12, IP65/67, NEMA 4X
XX	Special version

(6) Approval	
NA	Version for non-explosion-hazardous area inclusive approvals as overfill protection and leakage detection system acc. to WHG
CG	CSA General Purpose inclusive approvals as overfill protection and leakage detection system acc. to WHG

Additional Options

Service **	
S1	Cleaned from oil and grease
S2	Density setting > 0.5 g/cm ²
S3	Switching delay setting
S4	Special service

Test, certificate **	
S5	Material certificate, wetted metallic parts, EN 10204-3.1 inspection certificate
S6	Final inspection report
XX	Special version

Additional documents	
WH	Enclosed copies of approvals as overfill protection and leakage detection system acc. to WHG

Accessory optional	
Weld-in adapter	
PA	G3/4, d = 50, 316L, vessel installation
PB	G3/4, d = 50, 316L, vessel installation, EN 10204-3.1 inspection certificate
PC	G3/4, d = 29, 316L, pipe installation
PD	G3/4, d = 29, 316L, pipe installation, EN 10204-3.1 inspection certificate
PE	G1, d = 60, 316L, vessel installation
PF	G1, d = 60, 316L, vessel installation, EN 10204-3.1 inspection certificate
PG	G1, d = 53, 316L, pipe installation
PH	G1, d = 53, 316L, pipe installation, EN 10204-3.1 inspection certificate
Socket plug	
RZ	M12, elbowed 90 °, IP67, 5 m cable, slotted nut Cu Sn/Ni
R1	M12, IP67, 5 m cable, slotted nut Cu Sn/Ni
Additional accessories	
R5	Assembly socket wrench
ST	Test magnet
SZ	Special version

Marking	
S9	Tagging (TAG), see additional specifications

Mounting

Mounting position

The device can be installed in any position in a vessel, pipe or tank. Foam formation does not affect the function.

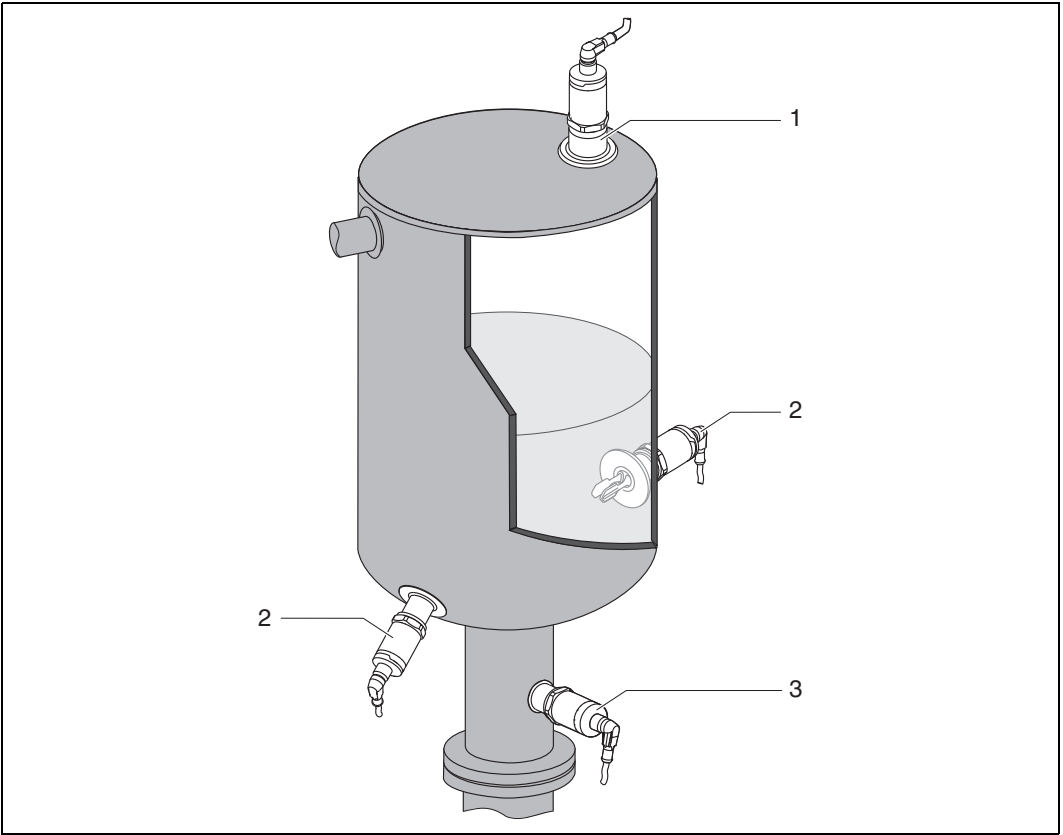

- 1 Overfill prevention or upper level detection
- 2 Lower level detection
- 3 Dry running protection for pump

Installation Conditions

The switch point (A) on the sensor depends on the orientation of the limit switch (water +25 °C (+77 °F), 1 bar (14.5 psi)).

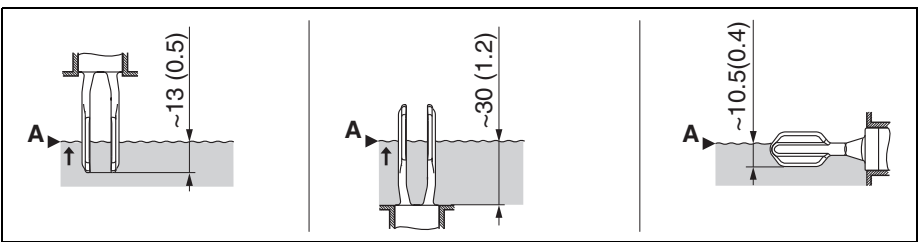

Vertical and horizontal orientation, dimensions in mm (inch)

Release date: 2023-09-11 Date of issue: 2023-09-11 Filename: 275573_eng.pdf

Refer to "General Notes Relating to Pepperl+Fuchs Product Information".