



Thru-beam sensor (pair)

OBE10M-R3-SE2-L



- Ultra-small housing design
- DuraBeam Laser Sensors - durable and employable like an LED
- 45° cable outlet for maximum mounting freedom under extremely tight space constraints
- Improvement in machine availability with abrasion-resistant, antistatic glass front

Laser thru-beam sensor, ultra-small design with M3 mounting, very high 10 m detection range, PNP output, 2 m fixed cable



Function

The R3 series nano sensor has been developed for a broad range of applications. It offers excellent durability and is exceptionally easy to install. The housing is compact and, with its 45° cable outlet, can be installed in the smallest spaces. New functional principles and functionality open up a range of new options. The DuraBeam laser sensors are durable and can be used in the same way as a standard sensor.

Dimensions

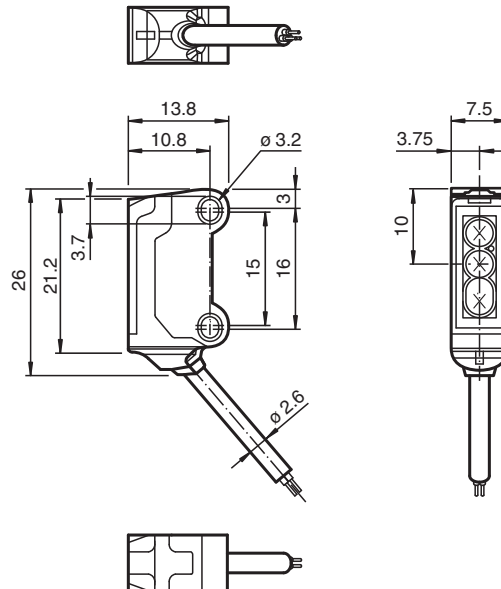

Technical Data

System components			
Emitter		OBE10M-R3-L	
Receiver		OBE10M-R3-E2-L	
General specifications			
Effective detection range		0 ... 10 m	
Threshold detection range		15 m	
Light source		laser diode	
Light type		modulated visible red light , 680 nm	
Laser nominal ratings			
Note		LASER LIGHT , DO NOT STARE INTO BEAM	
Laser class		1	
Wave length		680 nm	
Beam divergence		> 5 mrad	
Pulse length		approx. 3 μ s	
Repetition rate		approx. 16.6 kHz	
max. pulse energy		9.5 nJ	
Diameter of the light spot		approx. 20 mm at a distance of 10 m	
Opening angle		approx. 0.5 °	
Optical face		frontal	
Ambient light limit		EN 60947-5-2 : 30000 Lux	
Functional safety related parameters			
MTTF _d		806 a	
Mission Time (T _M)		20 a	
Diagnostic Coverage (DC)		0 %	
Indicators/operating means			
Operation indicator		LED green, statically lit Power on , short-circuit : LED green flashing (approx. 4 Hz)	
Function indicator		Receiver: LED yellow, lights up when light beam is free, flashes when falling short of the operating reserve ; OFF when light beam is interrupted	
Electrical specifications			
Operating voltage	U _B	12 ... 24 V	
No-load supply current	I ₀	Emitter: \leq 10 mA Receiver: \leq 8 mA	
Protection class		III	
Input			
Test input		Test of switching function at 0 V	
Switching threshold		Teach-In input	
Output			
Switching type		NO contact	
Signal output		1 PNP output, short-circuit protected, reverse polarity protected, open collector	
Switching voltage		max. 30 V DC	
Switching current		max. 50 mA , resistive load	
Voltage drop	U _d	\leq 1.5 V DC	
Switching frequency	f	approx. 2 kHz	
Response time		250 μ s	
Conformity			
Product standard		EN 60947-5-2	
Laser safety		EN 60825-1:2007	
Approvals and certificates			
EAC conformity		TR CU 020/2011	
UL approval		E87056 , cULus Recognized, Class 2 Power Source	
CCC approval		CCC approval / marking not required for products rated \leq 36 V	
FDA approval		IEC 60825-1:2007 Complies with 21 CFR 1040.10 and 1040.11 except for deviations pursuant to Laser Notice No. 50, dated June 24, 2007	
Ambient conditions			

Release date: 2022-08-25 Date of issue: 2022-08-25 Filename: 282078_eng.pdf

Refer to "General Notes Relating to Pepperl+Fuchs Product Information".

Pepperl+Fuchs Group
www.pepperl-fuchs.comUSA: +1 330 486 0001
fa-info@us.pepperl-fuchs.comGermany: +49 621 776 1111
fa-info@de.pepperl-fuchs.comSingapore: +65 6779 9091
fa-info@sg.pepperl-fuchs.com

PEPPERL+FUCHS

Technical Data

Ambient temperature	-20 ... 60 °C (-4 ... 140 °F)
Storage temperature	-30 ... 70 °C (-22 ... 158 °F)
Mechanical specifications	
Housing width	7.5 mm
Housing height	26 mm
Housing depth	13.8 mm
Degree of protection	IP67
Connection	2 m fixed cable
Material	
Housing	PC/ABS and TPU
Optical face	glass
Cable	PUR
Mass	approx. 20 g per sensor
Cable length	2 m

Connection

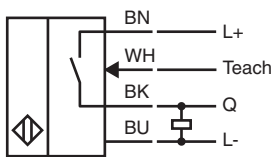
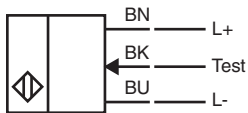

Assembly

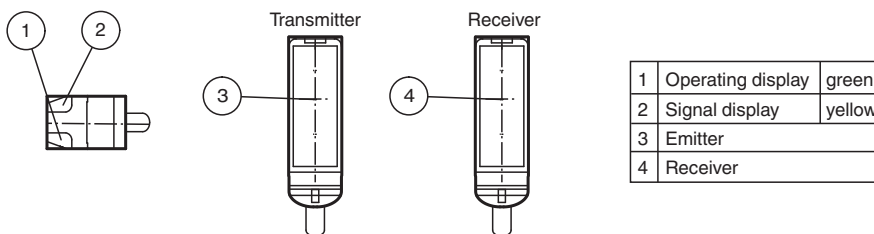

Release date: 2022-08-25 Date of issue: 2022-08-25 Filename: 282078_eng.pdf

Characteristic Curve

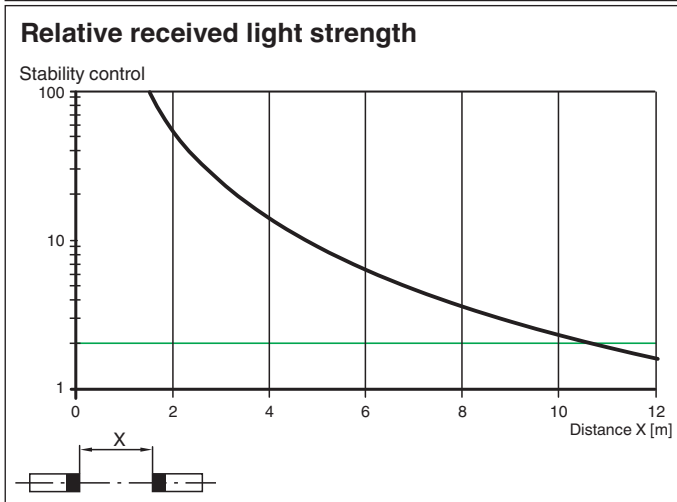
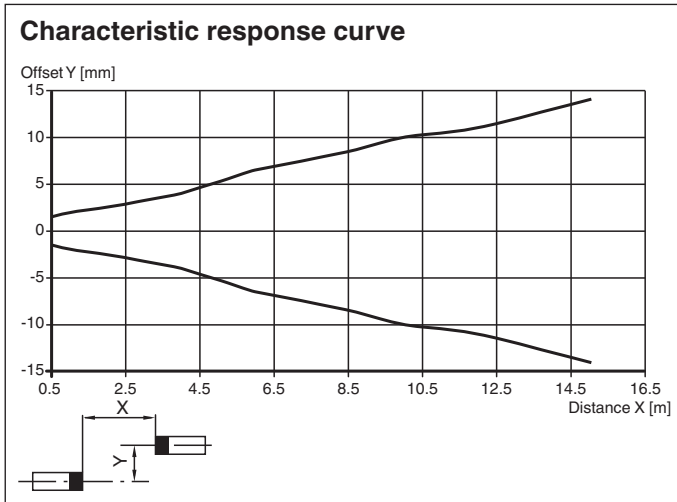





Safety Information



Release date: 2022-08-25 Date of issue: 2022-08-25 Filename: 282078_eng.pdf

Accessories

	MH-R3-01	Mounting aid for sensors from the R3 series, mounting bracket
	MH-R3-02	Mounting aid for sensors from the R3 series, mounting bracket
	MH-R3-03	Mounting aid for sensors from the R3 series, mounting bracket
	MH-R3-04	Mounting aid for sensors from the R3 series, mounting bracket

Release date: 2022-08-25 Date of issue: 2022-08-25 Filename: 282078_eng.pdf

Refer to "General Notes Relating to Pepperl+Fuchs Product Information".

Pepperl+Fuchs Group
www.pepperl-fuchs.com

USA: +1 330 486 0001
fa-info@us.pepperl-fuchs.com

Germany: +49 621 776 1111
fa-info@de.pepperl-fuchs.com

Singapore: +65 6779 9091
fa-info@sg.pepperl-fuchs.com

Teach-In

The thru-beam sensor enables the switching points to be taught in for optimum adaptation to specific applications. This eliminates the need for additional components such as apertures.

The sensitivity of the thru-beam sensor can be adjusted using three Teach-in methods:

Position Teach

When using this Teach-in method, the following settings are made on the thru-beam sensor:

- The gain is set to an optimum value
- The signal threshold is set to a minimum

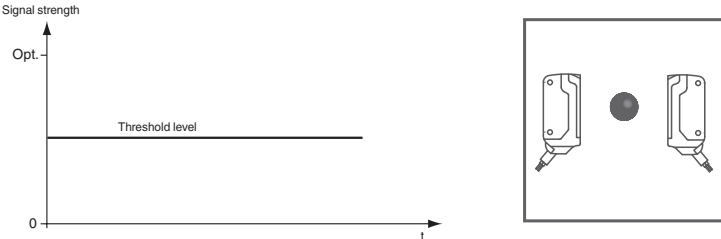

Recommended application:

This method enables minuscule particles in the beam path to be detected, and provides exceptional positioning accuracy. Make sure that there are no objects in the beam path and that the sensor is connected to the power supply.

1. Connect the white cable on the receiver (WH/IN) to the blue cable (BU/0 V) on the receiver. The green and yellow LED indicators flash simultaneously at 2.5 Hz
2. Disconnect the white cable on the receiver (WH/IN) from the blue cable (BU/0 V) on the receiver. The green and yellow LED indicators flash alternately at 2.5 Hz
3. The end of the Teach-in process is indicated when the green LED indicator lights up static and yellow LED blinks.

Two-Point Teach-In

When using this Teach-in method, the following settings are made on the thru-beam sensor:

- The gain is set to an optimum value
- The signal threshold is set in the center between the two taught signal values

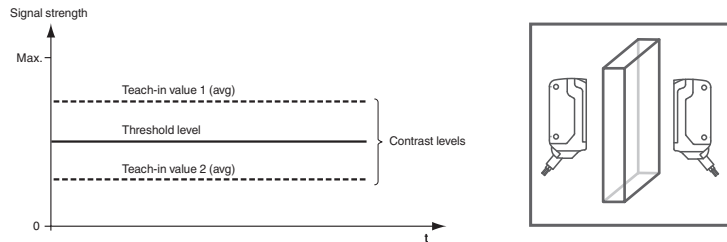

1. Make sure that there are no objects in the beam path and that the sensor is connected to the power supply.
2. Connect the white cable on the receiver (WH/IN) to the blue cable (BU/0 V) on the receiver. The green and yellow LED indicators flash simultaneously at 2.5 Hz
3. Position the object in the beam path.
4. Disconnect the white cable on the receiver (WH/IN) from the blue cable (BU/0 V) on the receiver. The green and yellow LED indicators flash alternately at 2.5 Hz
5. The end of the Teach-in process is indicated when the green LED indicator lights up static.

Maximum Teach-In

When using this Teach-in method, the following settings are made on the thru-beam sensor:

- The gain is set to a maximum
- The signal threshold is set to a minimum

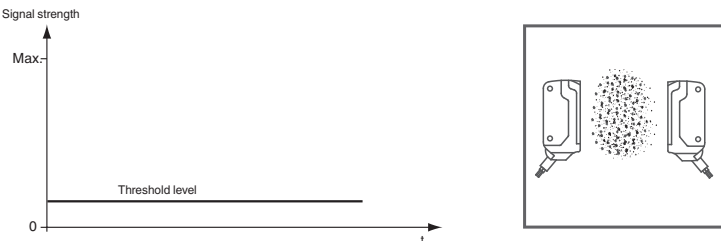

Recommended application:

Enables an object to be detected with a high excess gain. This can be useful if there is severe environmental contamination or to achieve long operating times.

Make sure that there are no objects in the beam path and that the sensor is connected to the power supply.

6. Cover the receiver or transmitter.
7. Connect the white cable on the receiver (WH/IN) to the blue cable (BU/0 V) on the receiver.

Release date: 2022-08-25 Date of issue: 2022-08-25 Filename: 282078_eng.pdf

Thru-beam sensor (pair)

OBE10M-R3-SE2-L

The green and yellow LED indicators flash simultaneously at 2.5 Hz

8. Disconnect the white cable on the receiver (WH/IN) from the blue cable (BU/0 V) on the receiver.
The green and yellow LED indicators flash alternately at 2.5 Hz
9. The end of the Teach-in process is indicated when the green LED indicator lights up static.