

Handheld (125 kHz)

IPT-HH27



- Suitable for IPC data carrier
- Robust design, suitable for indoor and outdoor use
- Simple handling via large touch display and keyboard
- Keypad for entry of alphanumeric characters
- Wide variety of helpful functions already available in the standard software
- Can be directly connected to the control panel or computer
- Option to create application-specific software

Handheld (125 kHz)



Dimensions

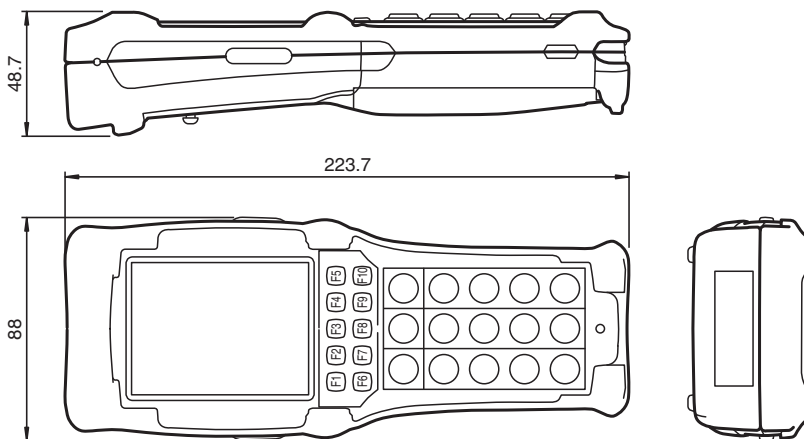

Technical Data

General specifications	
Description	Handheld with integrated LF read/write device, touch screen, WLAN, Bluetooth, Windows Embedded CE 6.0
Operating frequency	125 kHz
Nominal ratings	
Processor	Marvell PXA 166 XScale Processor
Clock pulse frequency	800 MHz
Memory	512 MB Flash ROM 256 MB RAM Micro SD card, 1 GB
Indicators/operating means	
Display	TFT color display with LED backlight, 3.5" Resolution 240 x 320 pixels
Keyboard	Keypad for entering alphanumeric characters
LED green	Device on
Key	Programmable function keys
Electrical specifications	
Battery type	Lithium polymer battery: 7.4 V; 2200 mAh



Release date: 2020-03-24 Date of issue: 2020-03-27 Filename: 283599_eng.pdf

Refer to "General Notes Relating to Pepperl+Fuchs Product Information".

Technical Data

Supply	Via docking station or from inserted Li polymer battery
Interface	
Interface type	Physical: USB connection and Ethernet connection via charger (accessories) Radio connection: WLAN IEEE 802.11 a/b/g, Bluetooth 2.0 + EDR
Directive conformity	
Radio equipment	
Directive 2014/53/EU	EN 301489-1 EN 301489-3 EN 300330 EN 62368-1 EN 50364
RoHS	
Directive 2011/65/EU (RoHS)	EN 50581
Standard conformity	
Degree of protection	EN 60529
RFID	ISO/IEC 18000-2
Approvals and certificates	
CE conformity	CE
Ambient conditions	
Ambient temperature	0 ... 45 °C (32 ... 113 °F)
Storage temperature	-20 ... 70 °C (-4 ... 158 °F)
Mechanical specifications	
Degree of protection	IP43
Material	
Housing	Plastic ABS
Mass	approx. 520 g
Dimensions	224 mm x 88 mm x 49 mm
Note	Li polymer battery included in scope of delivery Docking station and charger not included in scope of delivery

Matching system components

	IQZ-HH27-CHARGER1	Docking station for IQT1-HH27 and IPT-HH27
	IQZ-HH27-BAT	Lithium-polymer battery for IQT1-HH27 and IPT-HH27
	IQZ-HH27-BAT1	Lithium ion battery for IQT1-HH27 and IPT-HH27