

Features

- 2-channel signal conditioner
- 24 V DC supply (Power Rail)
- Input 2-wire SMART transmitters
- Output 0/4 mA ... 20 mA
- Terminal blocks with test sockets
- Up to SIL 2 acc. to IEC 61508

Function

This signal conditioner provides the isolation for non-intrinsically safe applications. The device supplies 2-wire SMART transmitters. It transfers the analog input signal as an isolated current value. Digital signals may be superimposed on the input signal and are transferred bi-directionally. If the HART communication resistance in the loop is too low, the internal resistance of 250 Ohm between terminals 8, 9 and 11, 12 can be used. Test sockets for the connection of HART communicators are integrated into the terminals of the device.

Application

- The device supports the following SMART protocols:
- HART
 - BRAIN
 - Foxboro

Assembly

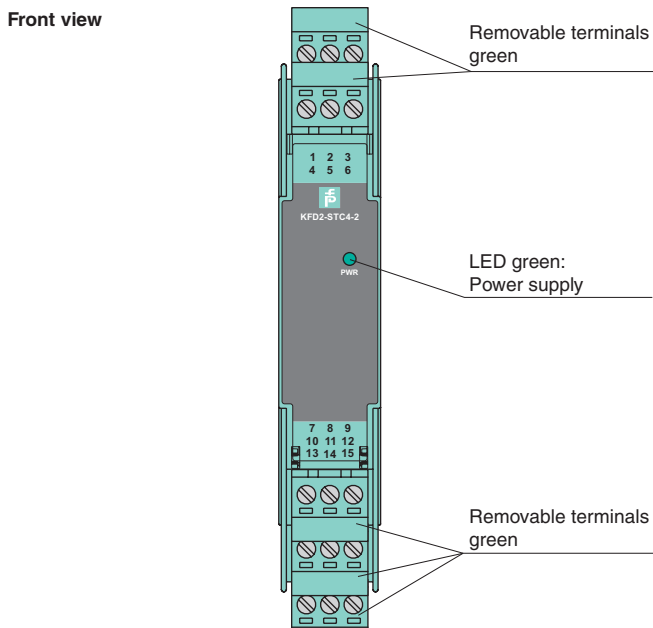

SIL 2

Connection

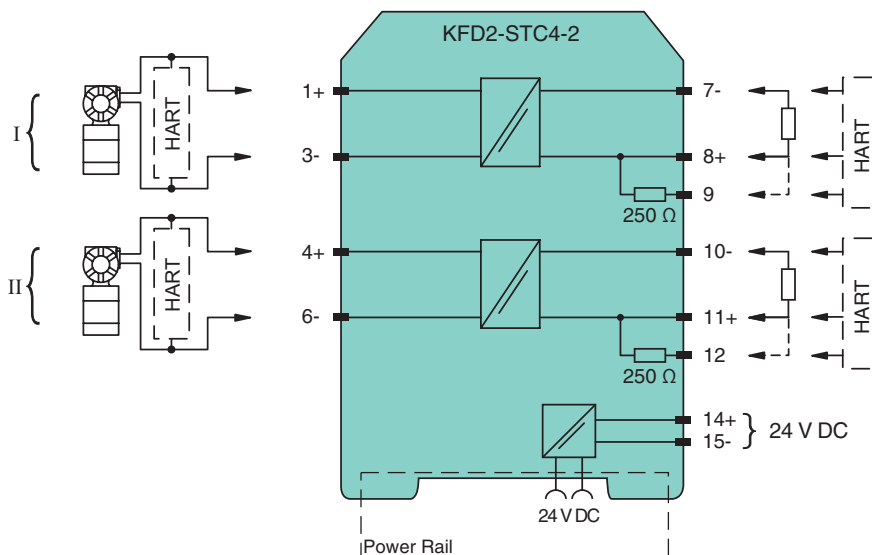

Release date 2017-08-09 14:35 Date of issue 2017-08-09 292439_eng.xml

Refer to "General Notes Relating to Pepperl+Fuchs Product Information".

General specifications	
Signal type	Analog input
Functional safety related parameters	
Safety Integrity Level (SIL)	SIL 2
Supply	
Connection	Power Rail or terminals 14+, 15-
Rated voltage U_r	20 ... 35 V DC
Ripple	within the supply tolerance
Power dissipation	1.8 W
Power consumption	≤ 2.7 W
Input	
Connection side	field side
Connection	terminals 1+, 3-; 4+, 6-
Input signal	0/4 ... 20 mA
Open circuit voltage/short-circuit current	terminals 1+, 3-; 4+, 6-: 22.1 V / 38 mA
Available voltage	terminals 1+, 3: ≥ 16 V at 20 mA
Output	
Connection side	control side
Connection	terminals 7-, 8+; 10-, 11+
Load	0 ... 550 Ω at 20 mA
Output signal	4 ... 20 mA (overload > 25 mA)
Ripple	≤ 50 μA _{rms}
Transfer characteristics	
Deviation	at 20 °C (68 °F), 0/4 ... 20 mA ≤ 10 μA incl. calibration, linearity, hysteresis, loads and fluctuations of supply voltage
Influence of ambient temperature	0.25 μA/K
Frequency range	input to output: bandwidth with 1 V _{pp} signal 0 ... 7.5 kHz (-3 dB) output to input: bandwidth with 1 V _{pp} signal 0.3 ... 7.5 kHz (-3 dB)
Settling time	200 μs
Rise time/fall time	20 μs
Galvanic isolation	
Input/Output	basic insulation according to IEC 61010-1, rated insulation voltage 300 V _{eff}
Input/power supply	basic insulation according to IEC 61010-1, rated insulation voltage 300 V _{eff}
Output/power supply	functional insulation, rated insulation voltage 50 V AC
Input/input	basic insulation according to IEC 61010-1, rated insulation voltage 300 V _{eff}
Output/Output	functional insulation, rated insulation voltage 50 V AC
Indicators/settings	
Display elements	LED
Labeling	space for labeling at the front
Directive conformity	
Electromagnetic compatibility	
Directive 2014/30/EU	EN 61326-1:2013 (industrial locations)
Conformity	
Electromagnetic compatibility	NE 21:2011
Degree of protection	IEC 60529:2001
Protection against electrical shock	EN 61010-1:2010
Ambient conditions	
Ambient temperature	-20 ... 60 °C (-4 ... 140 °F)
Mechanical specifications	
Degree of protection	IP20
Connection	screw terminals
Mass	approx. 150 g
Dimensions	20 x 124 x 115 mm (0.8 x 4.9 x 4.5 inch) , housing type B2
Mounting	on 35 mm DIN mounting rail acc. to EN 60715:2001
General information	
Supplementary information	Observe the certificates, declarations of conformity, instruction manuals, and manuals where applicable. For information see www.pepperl-fuchs.com .

Release date 2017-08-09 14:35 Date of issue 2017-08-09 292439_eng.xml

Accessories

Power feed module KFD2-EB2

The power feed module is used to supply the devices with 24 V DC via the Power Rail. The fuse-protected power feed module can supply up to 150 individual devices depending on the power consumption of the devices. Collective error messages received from the Power Rail activate a galvanically-isolated mechanical contact.

Power Rail UPR-03

The Power Rail UPR-03 is a complete unit consisting of the electrical insert and an aluminium profile rail 35 mm x 15 mm. To make electrical contact, the devices are simply engaged.

Profile Rail K-DUCT with Power Rail

The profile rail K-DUCT is an aluminum profile rail with Power Rail insert and two integral cable ducts for system and field cables. Due to this assembly no additional cable guides are necessary.



Power Rail and Profile Rail must not be fed via the device terminals of the individual devices!