

Control Unit Ex e, Panel Mount, Pushbutton

PMP.DZ3.C.11

- Double pushbutton, inserts with labeling: red '0', green 'I', black 'I', blue 'RESET'; without: white, amber - 1x NO / 1x NC
- Ex de and Ex tb certified
- Full equipment certified
- Polyamide housing for panel mount
- Installation in Zone 1, Zone 2, Zone 21 and Zone 22
- Cable Gland M20 integrated in protective cover
- Degree of protection IP66



Connection

	11	23
0	X	
I		X
	12	24

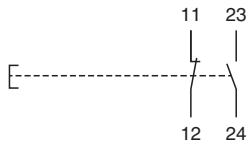

Dimensions

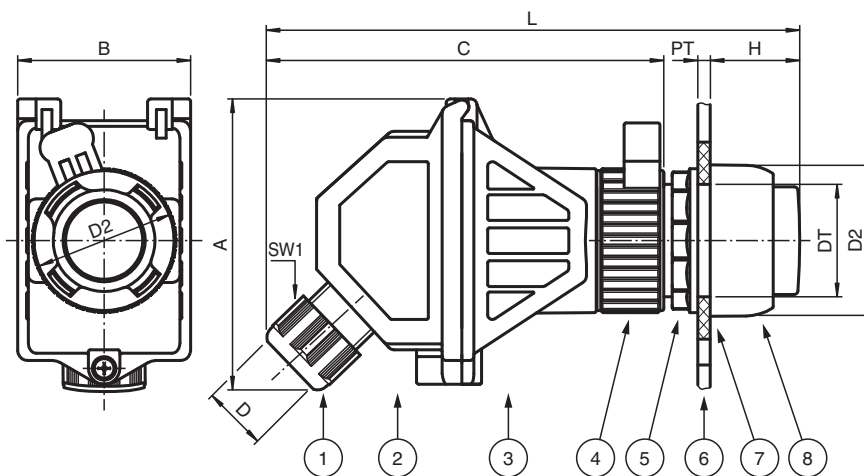

Release date: 2023-04-17 Date of issue: 2023-04-17 Filename: 297348_eng.pdf

Refer to "General Notes Relating to Pepperl+Fuchs Product Information".

Pepperl+Fuchs Group
www.pepperl-fuchs.com

USA: +1 330 486 0002
pa-info@us.pepperl-fuchs.com

Germany: +49 621 776 2222
pa-info@de.pepperl-fuchs.com

Singapore: +65 6779 9091
pa-info@sg.pepperl-fuchs.com

PF PEPPERL+FUCHS

Dimensions

Details see data table

Legend	
1	Cable gland
2	Protective cover
3	Contact module
4	Bayonet catch
5	Locknut
6	Panel / enclosure wall
7	Flat gasket
8	Actuator head
A	Height
B	Width
C	Depth
D	Clamping range, cable sheath diameter
DT	Diameter thru-hole
D2	Outer diameter actuator head
H	Length outside enclosure
L	Total length
PT	Panel / enclosure wall thickness

Technical Data

Electrical specifications

Operating voltage	250 V max.
Operating current	16 A max.
Terminal capacity	2x 2.5 mm ²
Terminal torque	0.8 Nm
Function	double pushbutton
Color	selection of red '0', green 'I', black 'I', blue 'RESET', white, amber
Contact configuration	1x NO / 1x NC all NC contacts have a direct opening action for emergency stop functions
Usage category	AC12 - 12 ... 250 V AC - 16 A AC15 - 12 ... 250 V AC - 10 A DC13 - 12 ... 110 V DC - 1 A DC13 - 12 ... 24 V DC - 1 A
Number of poles	2
Operator action	spring return

Mechanical specifications

Cable type	non-armored cables
Clamping range (D)	5.5 ... 13 mm (D)
Covering	Protective cover fully detachable
Cover fixing	Phillips head screw
Degree of protection	IP66
Cable entry	
Number of cable entries	1x M20 cable gland in protective cover
Material	
Housing	Polyamide (PA)
Finish	inherent color black
Seal	silicone
Washer gasket	silicone
Mass	150 g max.

Release date: 2023-04-17 Date of issue: 2023-04-17 Filename: 297348_eng.pdf

Refer to "General Notes Relating to Pepperl+Fuchs Product Information".

Pepperl+Fuchs Group
www.pepperl-fuchs.com

USA: +1 330 486 0002
pa-info@us.pepperl-fuchs.com

Germany: +49 621 776 2222
pa-info@de.pepperl-fuchs.com

Singapore: +65 6779 9091
pa-info@sg.pepperl-fuchs.com

 **PEPPERL+FUCHS**

Technical Data

Dimensions	
Height (A)	77 mm (A)
Width (B)	44 mm (B)
Depth (C)	105 mm (C)
Actuator head diameter (D2)	70 mm x 39 mm
Panel wall thickness (PT)	1 ... 6 mm (PT)
Diameter thru-hole (DT)	30.6 mm (DT)
Length outside enclosure (H)	15.5 mm (H)
Width across flats (SW1)	24 mm (SW1)
Total length (L)	128 mm (L)
Tightening torque	
Nut torque at enclosure (SW1)	2 Nm (SW1)
Mounting	via actuator head
Ambient conditions	
Ambient temperature	-40 ... 50 °C (-40 ... 122 °F)
Data for application in connection with hazardous areas	
EU-type examination certificate	CML 16 ATEX 3106X
Marking	Ⓜ II 2 GD Ex de IIC T6 Gb Ex tb IIIC T80 °C Db
International approvals	
IECEX approval	IECEX CML 16.0046X
UKCA approval	CML 21 UKEX 21275X
Conformity	
Degree of protection	EN 60529
Usage category	IEC / EN 60947
CE marking	0080 or 0102, see type label
General information	
Supplementary information	EC-Type Examination Certificate, Statement of Conformity, Declaration of Conformity, Attestation of Conformity and instructions have to be observed where applicable. For information see www.pepperl-fuchs.com .