

Incremental rotary encoder

ENI58IL-S06SA5-0200UD1-ACY:01N

- Housing Ø 58 mm
- Solid shaft
- Servo flange
- 200 ppr
- 10 V ... 30 V with short-circuit proof push-pull output
- BlueBeam technology for ultimate precision



Function

The ENI58IL impresses with its modular design, which is available over all mechanical and electrical interfaces. The ENI58IL is the best solution for all common applications, coupled with its high robustness, high reliability and versatility. With the high-precision BlueBeam technology and innovative housing design, the ENI58IL is the new market standard for incremental encoders. The electrical connection is made with a cable connector with Harting socket.

Dimensions

Servo flange

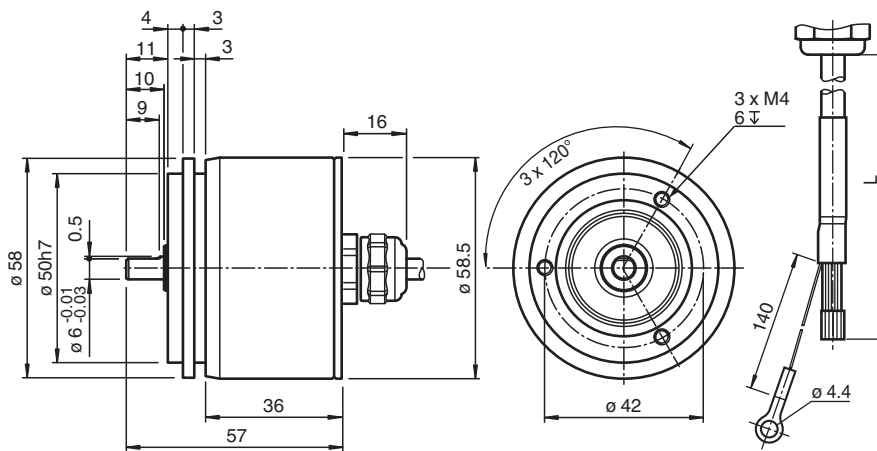

Technical Data

General specifications

Detection type	photoelectric sampling
Linearity error	$\pm 0.025^\circ$
Pulse count	200

Functional safety related parameters

MTTF _d	140 a
Mission Time (T _M)	20 a
L ₁₀	70 E+9 at 6000 rpm
Diagnostic Coverage (DC)	0 %

Electrical specifications

Operating voltage	U _B	10 ... 30 V DC
No-load supply current	I ₀	max. 50 mA

Release date: 2022-12-12 Date of issue: 2022-12-12 Filename: 323631_eng.pdf

Refer to "General Notes Relating to Pepperl+Fuchs Product Information".

Pepperl+Fuchs Group
www.pepperl-fuchs.com

USA: +1 330 486 0001
fa-info@us.pepperl-fuchs.com

Germany: +49 621 776 1111
fa-info@de.pepperl-fuchs.com







Singapore: +65 6779 9091
fa-info@sg.pepperl-fuchs.com

PF PEPPERL+FUCHS

Technical Data

Output	
Output type	push-pull, incremental
Load current	max. per channel 40 mA , short-circuit protected, reverse polarity protected
Output frequency	max. 400 kHz
Rise time	300 ns
Phase position A to B	
Pulse counts < 3600	90 ° ± 9 ° electrical
Pulse counts ≥ 3600	90 ° ± 15 ° electrical
Duty cycle	1/2 ± 10 %
Connection	
Cable	Ø6 mm, 6 x 0.14 mm ² , L = 0.3 m with Harting jacks (No. 09330006427)
Standard conformity	
Degree of protection	DIN EN 60529, IP65
Climatic testing	DIN EN 60068-2-78 , no moisture condensation
Emitted interference	EN 61000-6-4:2007/A1:2011
Noise immunity	EN 61000-6-2:2005
Shock resistance	DIN EN 60068-2-27, 300 g, 6 ms
Vibration resistance	DIN EN 60068-2-6, 30 g, 10 ... 2000 Hz
Ambient conditions	
Operating temperature	-40 ... 85 °C (-40 ... 185 °F) , fixed cable -5 ... 85 °C (23 ... 185 °F) , movable cable
Storage temperature	-40 ... 85 °C (-40 ... 185 °F)
Mechanical specifications	
Material	
Housing	3.2315 aluminum (AlMgSi1, saltwater-proof)
Flange	3.2315 aluminum (AlMgSi1, saltwater-proof)
Shaft	Solid shaft Stainless steel
Mass	< 300 g without cable
Rotational speed	max. 12000 min ⁻¹ for IP65
Moment of inertia	≤ 35 gcm ²
Starting torque	≤ 1 Ncm for IP65
Shaft load	
Axial	40 N at max. 6000 min ⁻¹ 10 N at max. 12000 min ⁻¹
Radial	80 N at max. 6000 min ⁻¹ 20 N at max. 12000 min ⁻¹

Accessories

	MBT-36ALS	Spring-loaded mounting bracket with a diameter of 36 mm
	9203	Angled flange
	9408 10*10	Double loop coupling 10 x 10
	V19-G-5M-PVC-TP	Female cordset, M12, 8-pin, shielded, PVC cable
	V19-G-2M-PVC-TP	Female cordset, M12, 8-pin, shielded, PVC cable
	V19-G-10M-PVC-TP	Female cordset, M12, 8-pin, shielded, PVC cable

Release date: 2022-12-12 Date of issue: 2022-12-12 Filename: 323631_eng.pdf

Refer to "General Notes Relating to Pepperl+Fuchs Product Information".

Pepperl+Fuchs Group
www.pepperl-fuchs.comUSA: +1 330 486 0001
fa-info@us.pepperl-fuchs.comGermany: +49 621 776 1111
fa-info@de.pepperl-fuchs.comSingapore: +65 6779 9091
fa-info@sg.pepperl-fuchs.com
 **PEPPERL+FUCHS**

Connection

Signal	Cable
GND	Grey
U _b	Brown
A	White
B	Green
Z	Yellow
Error	Pink (signal is static high)

Operation

Signal outputs

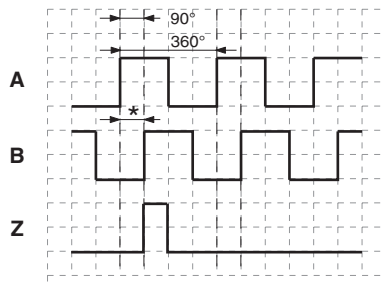

↺ cw - with view onto the shaft
 phase relationships electrical
 * 1 Measuring step is 90°

Additional Information

Anti-interference measures

The use of highly sophisticated microelectronics requires a consistently implemented anti-interference and wiring concept. This becomes all the more important the more compact the constructions are and the higher the demands are on the performance of modern machines.

The following installation instructions and proposals apply for "normal industrial environments". There is no ideal solution for all interfering environments.

When the following measures are applied, the encoder should be in perfect working order:

- With RS 422 Interface devices and long cables, a line-termination by a suitable termination resistor is required.
- A shielded cable should be used at installation. For the connection of RS 422 devices the wires must be twisted in pairs.
- The wiring of the encoder should be laid at a large distance to energy lines which could cause interferences.
- Cable cross-section of the screen at least 4 mm².
- Cable cross-section at least 0,14 mm².
- The wiring of the screen and 0 V should be arranged radially, if and when possible.
- Do not kink or jam the cables.
- Adhere to the minimum bending radius of 10 mm and avoid tensile as well as shearing load.

Operating instructions

Every encoder manufactured by Pepperl+Fuchs leaves the factory in a perfect condition. In order to ensure this quality as well as a faultless operation, the following specifications have to be taken into consideration:

- Avoid any impact on the housing and in particular on the encoder shaft as well as the axial and radial overload of the encoder shaft.
- The accuracy and service life of the encoder is guaranteed only, if a suitable coupling and / or torque support is used.
- Any wiring work has to be carried out with the system in a dead condition.
- The maximum operating voltages and output currents must not be exceeded. The devices have to be operated at extra-low safety voltage.
- Sensor wires are connected internally to the supply voltage and may be used for Voltage adjustment or -control in case of long cables.
- Unused sensor wires should either isolated or connected to the corresponding supply potentials (GND Sens connected to GND and U_b Sens connected to U_B).
- Unused outputs must be isolated before initial use of the encoder.

Notes on connecting the electric screening

The immunity to interference of a plant depends on the correct screening. In this field installation faults occur frequently. Often the screen is applied to one side only, and is then soldered to the earthing terminal with a wire, which is a valid procedure in LF engineering. However, in case of EMC the rules of HF engineering apply.

One basic goal in HF engineering is to pass the HF energy to earth at an impedance as low as possible as otherwise energy would discharge into the cable. A low impedance is achieved by a large-surface connection to metal surfaces.

The following instructions have to be observed:

- Apply the screen on both sides to a "common earth" in a large surface, if there is no risk of equipotential currents.
- The screen has to be passed behind the insulation and has to be clamped on a large surface below the tension relief.
- In case of cable connections to screw-type terminals, the tension relief has to be connected to an earthed surface.
- If plugs are used, metallised plugs only should be fitted (such as sub D plugs with metallised housing). Please observe the direct connection of the tension relief to the housing.

<p>Advantage:</p> <p>shield</p> <p>relief</p> <p>Disadvantage:</p>	<p>metallised connector,</p> <p>clamped with the strain</p> <p>clamp</p> <p>soldering shield on</p>
--	---

