

# Cable pull rotary encoder

## ECA10TL-03BNY-B20BD:01

- Cable drum anodized
- Plastic sheathed measuring cable
- Solid yet lightweight plastic construction
- Compact and very sleek design
- Coupling-free adaptation
- Very high level of linearity and repeatability
- CAN bus with SAE J1939 protocol

Cable pull rotary encoder with J1939 interface



### Function

Lighter and more solid cable pull rotary encoder with flat housing design.

### Dimensions

For design 80

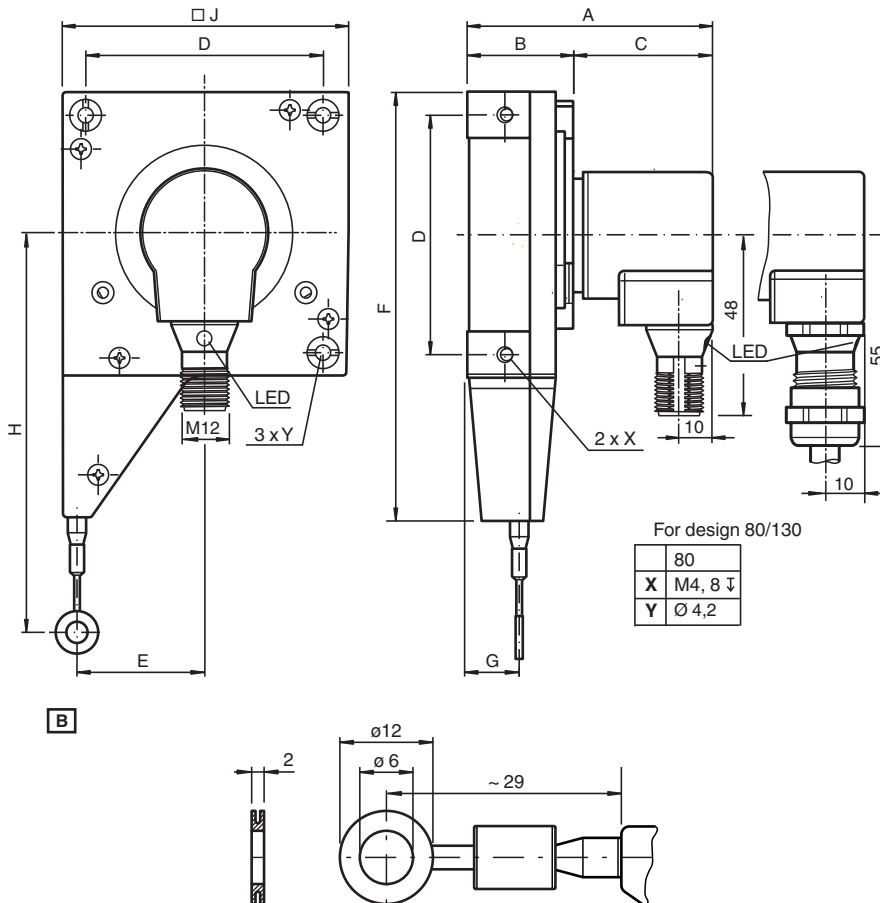

Release date: 2022-12-12 Date of issue: 2022-12-12 Filename: 324247\_eng.pdf

### Technical Data

#### General specifications

Detection type: magnetic sampling

Refer to "General Notes Relating to Pepperl+Fuchs Product Information".

Pepperl+Fuchs Group  
www.pepperl-fuchs.com

USA: +1 330 486 0001  
fa-info@us.pepperl-fuchs.com

Germany: +49 621 776 1111  
fa-info@de.pepperl-fuchs.com

Singapore: +65 6779 9091  
fa-info@sg.pepperl-fuchs.com

**PF** PEPPERL+FUCHS

## Technical Data

Device type		Target line with J1939 interface
Measuring range		3000 mm
Construction type		80 mm
Resolution		Cable pull: Design 80 mm: 0.056 mm Encoder: 24 bit (12 bit/revolution)
<b>Indicators/operating means</b>		
LED green		Operating mode
LED red		wrong baud rate
<b>Electrical specifications</b>		
Operating voltage	$U_B$	9 ... 30 V DC (with galvanic isolation)
Power consumption	$P_0$	≤ 1.2 W
Time delay before availability	$t_v$	< 250 ms
Output code		binary code
Code course (counting direction)		adjustable
<b>Interface</b>		
Interface type		J1939
Resolution		
Single turn		12 Bit
Multiturn		12 Bit
Overall resolution		24 Bit
Transfer rate		min. 20 kBit/s , max. 1 MBit/s
Cycle time		≥ 1 ms
Standard conformity		ISO 11898
<b>Connection</b>		
Connector		M12 connector, 5 pin
<b>Standard conformity</b>		
Degree of protection		acc. DIN EN 60529
Connection side		Encoder: IP65 Cable pull: IP50
Climatic testing		DIN EN 60068-2-3, no moisture condensation
Emitted interference		EN 61000-6-4:2007
Noise immunity		EN 61000-6-2:2005
<b>Ambient conditions</b>		
Ambient temperature		-30 ... 70 °C (-22 ... 158 °F)
Operating temperature		-30 ... 70 °C (-22 ... 158 °F)
Storage temperature		-30 ... 70 °C (-22 ... 158 °F)
Relative humidity		98 % , no moisture condensation
<b>Mechanical specifications</b>		
Rope diameter		0.55 mm
Material		
Housing		nickel-plated steel
Cable pull		Luranyl® or Lexan 920
Flange		Aluminum
Rope		Stainless steel 1.4401/316, PA sheathing
Life span		up to 10 <sup>6</sup> Cycles

**Connection**

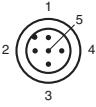
Signal	5-pin, M12 x 1 connector
CAN GND	1
+V <sub>S</sub>	2
GND	3
CAN-High	4
CAN-Low	5
Shielding	Housing
Pinout	

**Dimensions**

**Variable Data and Dimensions**

Technical data	Design 80
Measuring length (in m)	03
Drum size (incl. cable) (in mm)	230
Retraction speed (in m/s)	6
Spring retraction force (in N)	5-6.3
Weight (in kg)	0.4
Rotary encoder Ø (in mm)	36
<b>Dimensions (in mm)</b>	
A	67
B	30
C	37
D	67
E	36
F	120
G	14.5
H	106
J	80

**Interface**

**Example of the transmit commands**

Command	Identifier	Data	Comments
Read request Direction	18EA2000	01 EF 00 00 00 00 00 00	
Read request Node	18EA2000	08 EF 00 00 00 00 00 00	
Write Direction	00EF2000	01 01 00 00 00 FF FF FF (CCW increase position)	When you change direction it will give you a different positional value. You will then need to set your preset value.
Write PRESET	00EF2000	04 A8 61 00 00 FF FF FF (value 25.000)	The preset value should be received at positional value 18FFAA20.
Write Save	00EF2000	FA 73 61 76 65 FF FF FF	The settings saved in non-volatile memory

If you change the node number, you will need to cycle power (after you save your settings) for the node number to change. Once you cycle power, you will need to enter the new node number in your identifier. You can confirm everything is saved in non-volatile memory by cycling power.

**Receive:**

Release date: 2022-12-12 Date of issue: 2022-12-12 Filename: 324247\_eng.pdf

Refer to "General Notes Relating to Pepperl+Fuchs Product Information".

# Cable pull rotary encoder

ECA10TL-03BNY-B20BD:01

18FFAA20: Positional and speed data  
18EA2000: Read response

Release date: 2022-12-12 Date of issue: 2022-12-12 Filename: 324247\_eng.pdf

Refer to "General Notes Relating to Pepperl+Fuchs Product Information".

Pepperl+Fuchs Group  
www.pepperl-fuchs.com

USA: +1 330 486 0001  
fa-info@us.pepperl-fuchs.com

Germany: +49 621 776 1111  
fa-info@de.pepperl-fuchs.com

Singapore: +65 6779 9091  
fa-info@sg.pepperl-fuchs.com

 **PEPPERL+FUCHS**