



Model Number

DAD30-RT-W

Optical data coupler

Features

- Compact, flat aluminium housing
- 3 interfaces in a device can be selected via DIP switches
- Visible red light
- Mating connector with protective cover included delivery

Dimensions

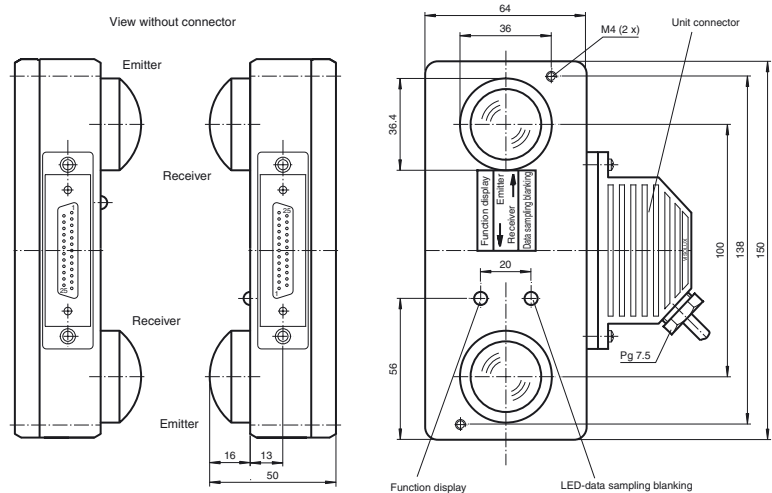

Electrical connection

Option:

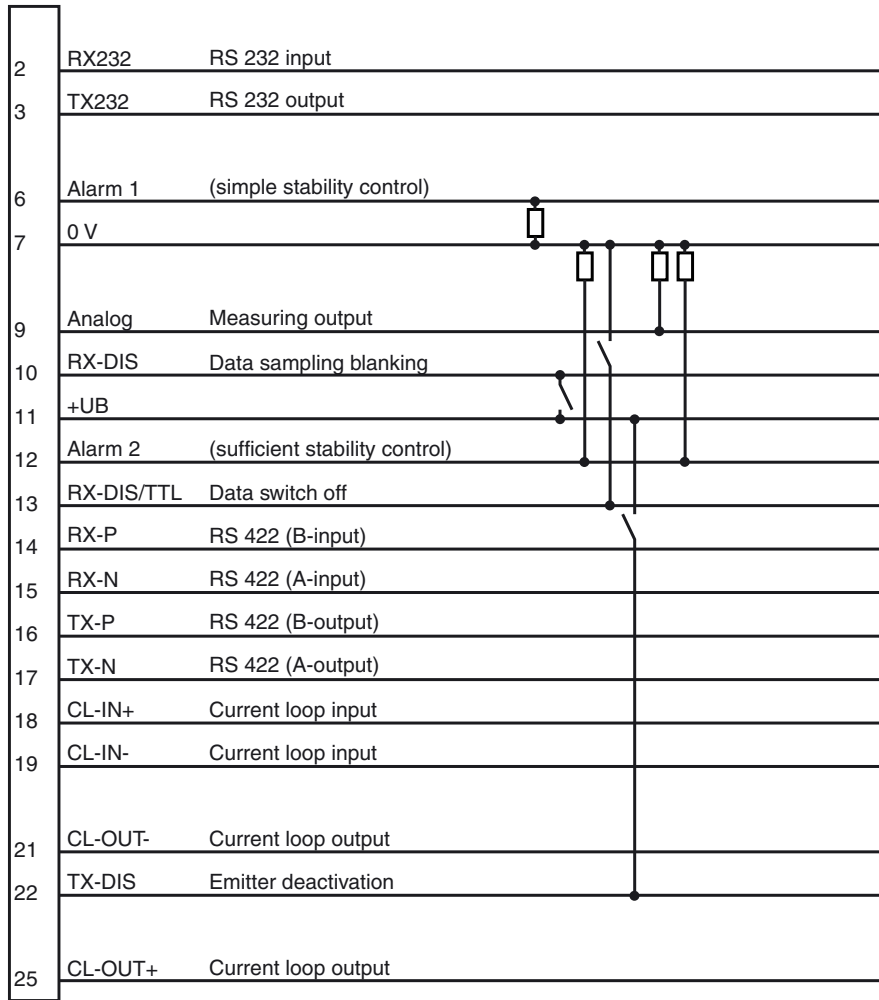

Release date: 2006-02-22 11:25 Date of issue: 2011-02-17 418451_ENG.xml

Technical data

General specifications

Effective detection range	0 ... 15 m
Threshold detection range	20 m
Light source	LED
Light type	modulated visible red light
Approvals	CE
Alignment aid	with function display
Transmission mode	FSK
Response delay	40 μ s
Diameter of the light spot	4200 mm at a distance of 15 m
Angle of divergence	Emitter: 16 ° Receiver: 16 °
Ambient light limit	30000 Lux

Indicators/operating means

Function display	LED red: switch point LED green: sufficient stability control
Controls	8-fold DIP-switch for selection of transmission frequency and interface

Electrical specifications

Operating voltage	U_B	24 V DC \pm 25 %
No-load supply current	I_0	200 mA
Data sampling blanking		Input for incoming data blanking with +24 V DC
Data rate		0 ... 19.2 kBit/s
Operation frequency		F1 = 83 kHz F2 = 118 kHz

Interface

Interface type	RS 232, RS 422, CL20 mA active/passive switchable
----------------	---

Output

Output of the pre-fault indication	2 PNP-outputs, short-circuit protected, 30 V DC 0.1 A activated for single or sufficient stability control
Measurement output	+1.8 ... 5.8 V DC, max. 10 mA, simple stability control: 2.5 V triple stability control: 4.2 V

Standard conformity

Standards	EN 60947-5-2
-----------	--------------

Ambient conditions

Ambient temperature	-20 ... 60 °C (-4 ... 140 °F)
Storage temperature	-20 ... 75 °C (-4 ... 167 °F)

Mechanical specifications

Protection degree	IP65
Connection	25-pin Sub-D connector
Material	
Housing	aluminium
Optical face	glass
Mass	500 g

Curves/Diagrams

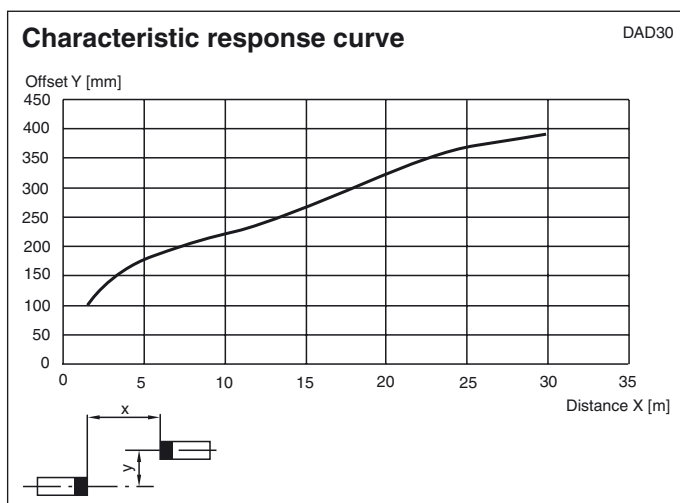

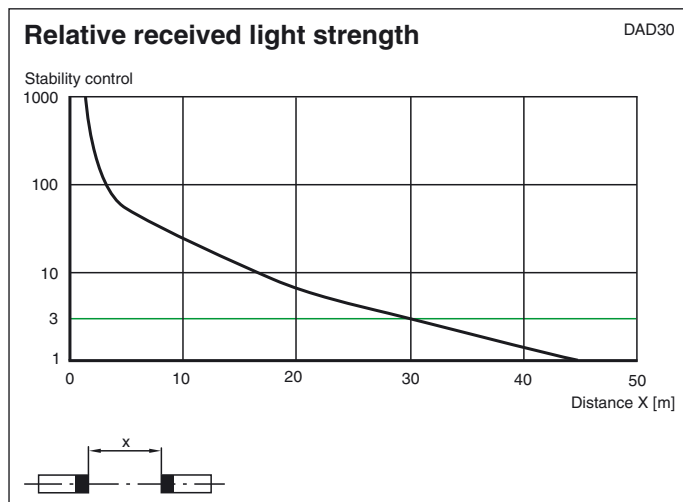

Function

The DAD 30 is a device for serial data transfer for data rates up to 19.2 kBaud and ranges up to 100 m. The device can also be used without problems for data rates and effective operating distances below these values. The transmission is protocol-free. If two full-duplex routes are to be installed in parallel, infrared should be selected for one route and visible emitter light for the other.

Data transfer

In order to avoid mutual interference of the two transfer channels, emitter and receiver of a device are operated at different centre frequencies F1/F2. The frequency is adjusted with the S1 DIP switch..

S1: ON = emitter F1, receiver F2
OFF = emitter F2, receiver F1

LED functional display / functional reserve

A two-color LED is used as the functional and alignment control. It is lit and red if the level of the received signal is assured for a simple transfer. If the LED is lit and green, sufficient functional reserve is present. The indicator is independent of the data transfer.

Interface

The DAD30 contains a standard interface module for serial transfer. The data lines have to be connected to the corresponding pins of the connector according to the desired interface. All output interfaces are controlled at the same time. To select the input interface, the appropriate DIP switch S4-S6 should be moved to the ON position.

20-mA electrical circuit (CL)

S4: ON = data in, 20 mA current loop

Serial interface with defined current level (Low = 0 mA, High = 20 mA) and for connection to an opposite station. It transfers data on lines over lengths of up to 1 km. With the DAD 30, the 20 mA interfaces can be operated in either active or passive mode.

For the selection the DIP switches S7 and S8 are used.

The interface, that feeds the current is designated as active. Only one of the two communication partners can be active (optical data coupler or control system). By means of the DIP-switches S7 and S8 the DAD 30 can be operated with active as well as with passive CL 20 mA interface. It is also possible to operate one interface in the active mode and the other one in the passive mode.

Example:

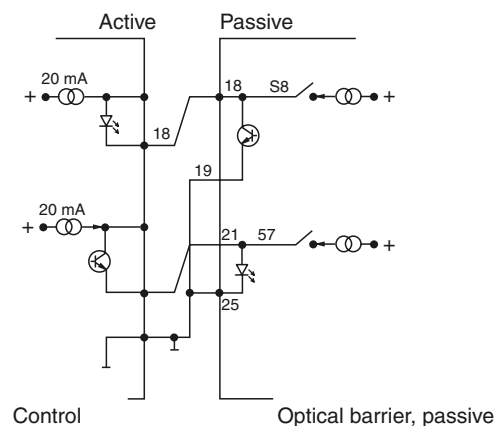

S7: ON = input interface active, 20 mA current loop
OFF= input interface passive

S8: ON = output interface active, 20 mA current loop
OFF= output interface passive

RS 422

S5: ON = data in, RS 422

Serial voltage interface, suited for rapid transmission over great distances (up to 1.5 km). The logical states can be defined by comparing voltages.

RS 232

S6: ON = data in, RS 232

Serial voltage interface (one or two data lines) with the normal levels in the PC periphery (low = 3 to 15V, high = -3 V to -15 V), in reference to a common ground. It is designed for distances of up to 20 m in range and connection to an opposite station.

Caution! Only one of the switches S4–S6 should be turned on!

With either one S2 or S3 switch, it is possible to invert data signals for special applications.

S2 ON = input signal of the emitter, inverted
OFF = input signal of the emitter, not inverted

S3 ON = output signal of the receiver, inverted
OFF = output signal of the receiver, not inverted

When the light beam is interrupted, the light beam switch on the receiver side goes into pause status. This status is logically high for non-inverted data lines, in other words for the RS 232 – 3 V ... 15 V interface, for the RS 422 interface, the difference in level is under 3 V ($A \leq B$) and for the CL-interface a conducting 20 mA electrical circuit.

All previously defined switching positions can be set with the programming switch (S1-S8), which is located on the print. The programming switch is visible on the print after the housing cover has been removed.

Data blanking receiver

An additional input is available for blanking the received data. This input must be wired with high level (+24 V) to activate blanking. Blanked status is indicated by a red LED.

Connector bar:

