

# Digital Input

## LB1102A



- 3-channel
- Inputs Ex ia
- Mounting in Zone 2, Class I/Div.2 or in the safe area
- Dry contact or NAMUR inputs
- Positive or negative logic selectable
- Simulation mode for service operations (forcing)
- Line fault detection (LFD)
- Permanently self-monitoring
- Module can be exchanged under voltage



### Function

The device accepts up to 3 digital input signals of NAMUR sensors or mechanical contacts from the hazardous area. Open or short circuit line fault alarms are detected. The inputs are galvanically isolated from the bus and the power supply (EN 60079-11).

### Connection

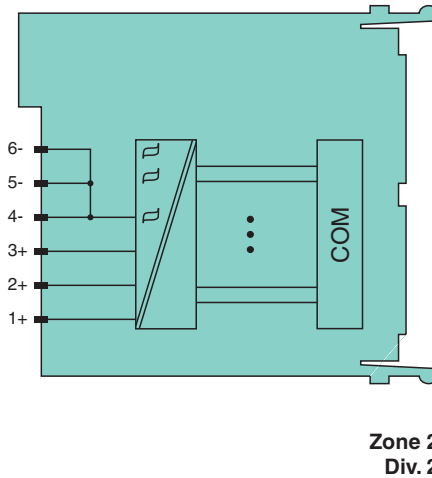
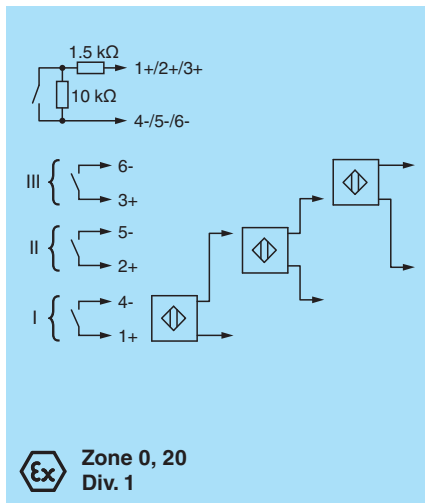

### Technical Data

<b>Slots</b>	
Occupied slots	1
<b>Supply</b>	
Connection	backplane bus
Rated voltage	$U_r$ 12 V DC , only in connection with the power supplies LB9***
Power dissipation	0.75 W
Power consumption	0.75 W
<b>Internal bus</b>	
Connection	backplane bus
Interface	manufacturer-specific bus to standard com unit
<b>Digital input</b>	
Number of channels	3
Sensor interface	

Release date: 2023-10-19 Date of issue: 2023-10-19 Filename: 5411934\_eng.pdf

Refer to "General Notes Relating to Pepperl+Fuchs Product Information".

Pepperl+Fuchs Group  
www.pepperl-fuchs.com

USA: +1 330 486 0002  
pa-info@us.pepperl-fuchs.com

Germany: +49 621 776 2222  
pa-info@de.pepperl-fuchs.com

Singapore: +65 6779 9091  
pa-info@sg.pepperl-fuchs.com

**PEPPERL+FUCHS**

## Technical Data

Connection	NAMUR sensor	
Connection [2]	voltage-free contact	
Connection [3]	active binary signal 24 V DC	
Connection	channel I: 1+, 4-; channel II: 2+, 5-; channel III: 3+, 6-	
Rated values	acc. to EN 60947-5-6 (NAMUR)	
Switching point/switching hysteresis	1.2 ... 2.1 mA / ± 0.2 mA	
Voltage	8.2 V	
Internal resistor	R <sub>i</sub>	1 kΩ
Line fault detection	can be switched on/off for each channel via configuration tool	
Connection	mechanical switch with additional resistors (see connection diagram) proximity switches without additional wiring	
Short-circuit	< 360 Ω	
Open-circuit	< 0.35 mA	
Minimum pulse duration	20 ms	
<b>Indicators/settings</b>		
LED indication	LED green: supply LED red: line fault, per channel LED yellow: signal (status), per channel	
Coding	optional mechanical coding via front socket	
<b>Directive conformity</b>		
Electromagnetic compatibility		
Directive 2014/30/EU	EN 61326-1:2013	
<b>Conformity</b>		
Electromagnetic compatibility	NE 21	
Degree of protection	IEC 60529	
Environmental test	EN 60068-2-14	
Shock resistance	EN 60068-2-27	
Vibration resistance	EN 60068-2-6	
Damaging gas	EN 60068-2-42	
Relative humidity	EN 60068-2-78	
<b>Ambient conditions</b>		
Ambient temperature	-20 ... 60 °C (-4 ... 140 °F)	
Storage temperature	-25 ... 85 °C (-13 ... 185 °F)	
Relative humidity	95 % non-condensing	
Altitude	max. 2000 m	
Shock resistance	shock type I, shock duration 11 ms, shock amplitude 15 g, number of shocks 18	
Vibration resistance	frequency range 10 ... 150 Hz; transition frequency: 57.56 Hz, amplitude/acceleration ± 0.075 mm/1 g; 10 cycles frequency range 5 ... 100 Hz; transition frequency: 13.2 Hz amplitude/acceleration ± 1 mm/0.7 g; 90 minutes at each resonance	
Damaging gas	designed for operation in environmental conditions acc. to ISA-S71.04-1985, severity level G3	
<b>Mechanical specifications</b>		
Degree of protection	IP20 when mounted on backplane	
Connection	removable front connector with screw flange (accessory) wiring connection via spring terminals (0.14 ... 1.5 mm <sup>2</sup> ) or screw terminals (0.08 ... 1.5 mm <sup>2</sup> )	
Mass	approx. 90 g	
Dimensions	16 x 100 x 102 mm (0.63 x 3.9 x 4 inch)	
<b>Data for application in connection with hazardous areas</b>		
EU-type examination certificate	PTB 03 ATEX 2042 X	
Marking	Ⓜ II (1)G [Ex ia Ga] IIC Ⓜ II (1)D [Ex ia Da] IIIC Ⓜ I (M1) [Ex ia Ma] I	
Input		
Voltage	U <sub>o</sub>	10.5 V
Current	I <sub>o</sub>	35 mA

Release date: 2023-10-19 Date of issue: 2023-10-19 Filename: 541934\_eng.pdf

Refer to "General Notes Relating to Pepperl+Fuchs Product Information".

Pepperl+Fuchs Group  
www.pepperl-fuchs.comUSA: +1 330 486 0002  
pa-info@us.pepperl-fuchs.comGermany: +49 621 776 2222  
pa-info@de.pepperl-fuchs.comSingapore: +65 6779 9091  
pa-info@sg.pepperl-fuchs.com

**PEPPERL+FUCHS**

**Technical Data**

Power	P <sub>o</sub>	92 mW
Certificate		PF 08 CERT 1234 X
Marking		Ⓜ II 3 G Ex nA IIC T4 Gc
Galvanic isolation		
Input/power supply, internal bus		safe electrical isolation acc. to EN 60079-11, voltage peak value 375 V
Directive conformity		
Directive 2014/34/EU		EN IEC 60079-0:2018+AC:2020 EN 60079-11:2012 EN 60079-15:2010
<b>International approvals</b>		
ATEX approval		PF 08 CERT 1234 X PTB 03 ATEX 2042 X
UL approval		E106378
Control drawing		116-0321
Approved for		cUL (Canada): CL I Zn. 2 IIC; IS circuits for CL I Zn. 0 IIC ULus (USA): CL I Div. 2 Grp. A, B, C, D; IS circuits for CL I, II, III Div. 1 Grp. A, B, C, D, E, F, G
<b>IECEX approval</b>		
IECEX certificate		IECEX BVS 09.0037X
IECEX marking		Ex nA [ia Ga] IIC T4 Gc [Ex ia Da] IIC [Ex ia Ma] I
<b>General information</b>		
System information		The module has to be mounted in appropriate backplanes (LB9***) in Zone 2 or outside hazardous areas. Here, observe the corresponding declaration of conformity. For use in hazardous areas (e. g. Zone 2, Zone 22 or Div. 2) the module must be installed in an appropriate enclosure.
Supplementary information		EC-Type Examination Certificate, Statement of Conformity, Declaration of Conformity, Attestation of Conformity and instructions have to be observed where applicable. For information see <a href="http://www.pepperl-fuchs.com">www.pepperl-fuchs.com</a> .

**Assembly**

**Front view**

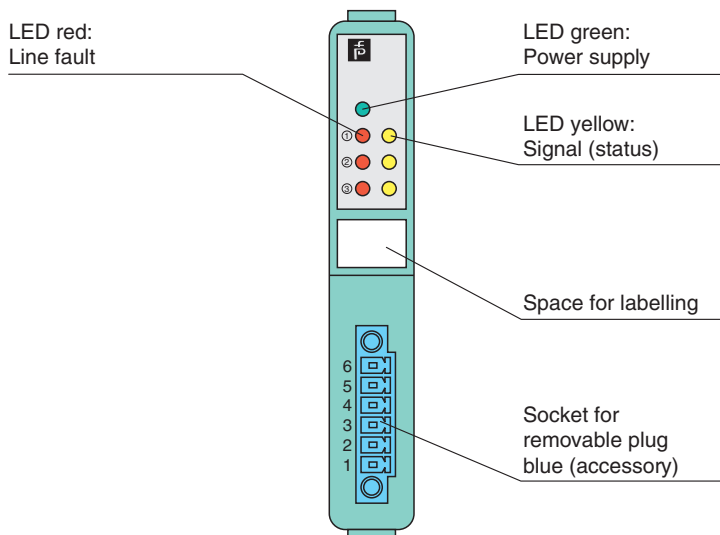

Release date: 2023-10-19 Date of issue: 2023-10-19 Filename: 541934\_eng.pdf