



Wireless ultrasonic sensor

WILSEN.sonic.distance

WS-UCC2500-F406-B41-01-02-Y

- Battery operated
- Data transfer via LoRaWAN
- LoRaWAN downlink channel for querying and adjusting parameter values
- Bluetooth interface for commissioning, parameterization and diagnostics

Wireless ultrasonic sensor with LoRaWAN interface, especially for level monitoring in rivers and distance measurement , sensing range 150 ... 2500 mm, resolution 1 mm



Function

The wireless ultrasonic sensor can be remotely used for fill level measurement, level monitoring and distance measurement. The measured variables and other measurement and status data of the sensor are recorded in configurable time intervals and transmitted to a counterpart in the LoRa network. There, the data is available for pure display or further processing. The sensor's downlink channel can be used to remotely access the sensor from the LoRa network to query or adjust sensor parameter values. Sensor parameterization is additionally also possible via the integrated Bluetooth interface using a mobile device (smartphone or tablet) and the WILSEN app associated with the sensor.

Dimensions

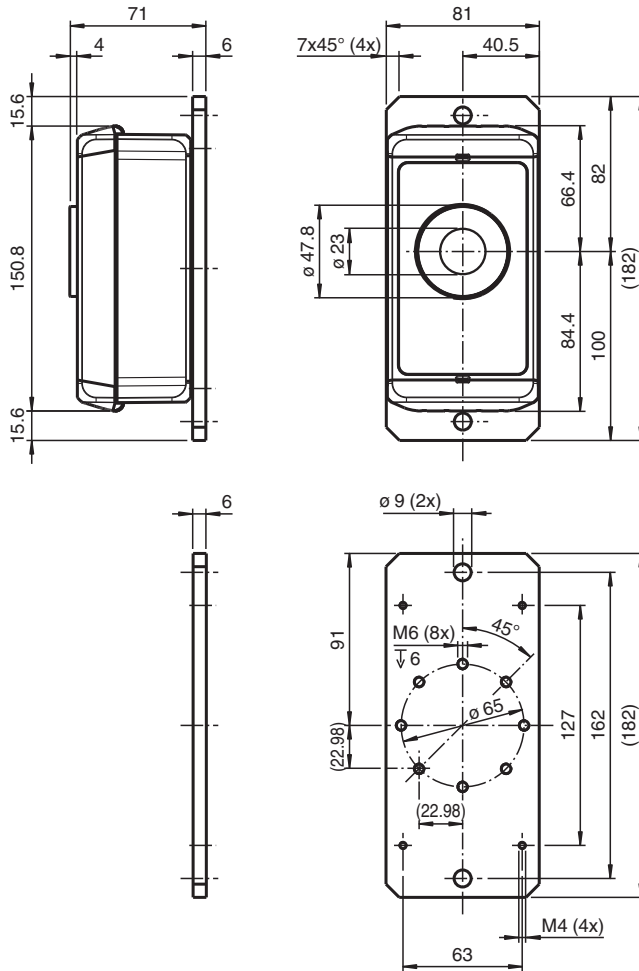

Technical Data

Main sensor	
Detection type	ultrasonic
Sensing range	150 ... 2500 mm
Dead band	0 ... 150 mm
Resolution	1 mm
Measurement interval	10 min ... 24 h
Integrated sensor technology	
GPS sensor	for geo-positioning
Acquisition interval	30 min ... 24 h
Temperature sensor	
Resolution	0.5 °C
Accuracy	± 2 °C
Electrical specifications	
Power supply	high capacity lithium battery 3.6 V , 13000 mAh battery lifetime approx. 10 years under Central European environmental conditions, 3 measurements and 3 wireless transmission per day with sufficient network coverage.
Interface 1	
Interface type	Bluetooth 5.0 LE
Transmitter radiated power	+ 8 dBm
Frequency range	2402 ... 2480 MHz
Interface 2	
Interface type	LoRaWAN
Specification	LoRaWAN interface specification V1.0.3

Release date: 2024-03-19 Date of issue: 2024-03-19 Filename: 70150489_eng.pdf

Refer to "General Notes Relating to Pepperl+Fuchs Product Information".

Technical Data

Device type	LoRaWAN class A device
Downlink channel	yes
Transmitter frequency	868 MHz
Transmitter radiated power	+ 8 dBm
Frequency range	863 ... 870 MHz (Europe)
Transmission interval	10 min ... 24 h
Directive conformity	
Electromagnetic compatibility	
Directive 2014/30/EU	EN 301 489-1 V2.2.3:2019 EN 301 489-3 V2.1.1:2019 EN 301 489-17 V3.2.4:2020 EN 301 489-19 V2.1.1:2019
Radio and telecommunication terminal equipment	
Directive 2014/53/EU	EN 300 220-2 V3.1.1:2017 EN 300 328 V2.2.2:2019 EN 303 413 V1.1.1:2017
RoHS	
Directive 2011/65/EU (RoHS)	EN 63000:2018
Conformity	
Mech. capacity	EN 60947-5-2:2020 IEC 60947-5-2:2019
Shock resistance	EN 60947-5-2:2020 IEC 60947-5-2:2019
Vibration resistance	EN 60947-5-2:2020 IEC 60947-5-2:2019
Climatic conditions	EN 60947-5-2:2020 IEC 60947-5-2:2019
Ambient conditions	
Ambient temperature	-25 ... 70 °C (-13 ... 158 °F)
Storage temperature	-40 ... 85 °C (-40 ... 185 °F)
Mechanical specifications	
Degree of protection	IP66 / IP67
Material	
Housing	PC (UL94-V0)
Transducer	PTFE coated housing: PBT
Mass	620 g
Dimensions	
Height	70 mm
Width	81 mm
Length	182 mm
Factory settings	
Beam width	wide
Transmission interval	24 h
Measurement interval	24 h

Release date: 2024-03-19 Date of issue: 2024-03-19 Filename: 70150489_eng.pdf

Characteristic Curve

Characteristic response curve

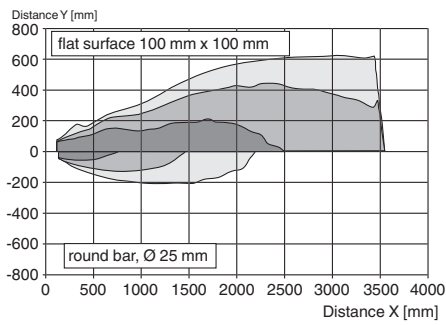

Additional Information

Further Documentation

For commissioning, parameterization and usage of the sensor, there are also a brief commissioning instructions, a manual and further technical information for download from the product page at www.pepperl-fuchs.com.

Release date: 2024-03-19 Date of issue: 2024-03-19 Filename: 70150489_eng.pdf