



# Incremental Encoder for special applications

## RHI58N-\*\*\*\*\*X

- Industrial standard housing Ø58 mm
- Up to 50,000 ppr
- Hollow shaft
- 10 V ... 30 V with RS 422 interface
- Up to 5000 ppr



### Function

High performance are key words for this rotary encoder. Its outstanding feature is the-high resolution angle. Usually all six output channels of this incremental rotary encoder are assigned to ensure flexible use of the encoder in a wide range of applications. This incremental rotary encoder is available as hollow shaft design with a shaft Ø10 mm, Ø12 mm or Ø15 mm. The rotary encoder is held in place by an included torque rest. The electrical connection is made with a cable connector.

### Dimensions

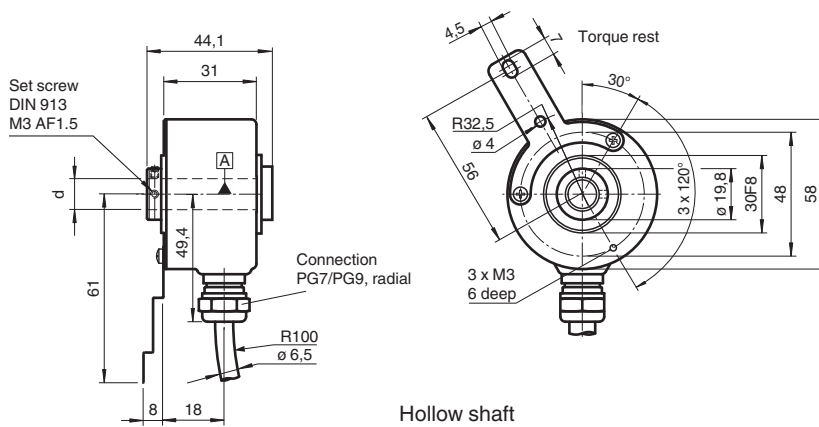

Hollow shaft

### Technical Data

General specifications		
Detection type	photoelectric sampling	
Pulse count	max. 50000	
Functional safety related parameters		
MTTF <sub>d</sub>	140 a	
Mission Time (T <sub>M</sub> )	20 a	
L <sub>10</sub>	70 E+9 at 6000 rpm	
Diagnostic Coverage (DC)	0 %	
Electrical specifications		
Operating voltage	U <sub>B</sub>	10 ... 30 V DC
No-load supply current	I <sub>0</sub>	max. 50 mA

Release date: 2022-12-12 Date of issue: 2022-12-12 Filename: t151831\_eng.pdf

Refer to "General Notes Relating to Pepperl+Fuchs Product Information".

Pepperl+Fuchs Group  
www.pepperl-fuchs.com

USA: +1 330 486 0001  
fa-info@us.pepperl-fuchs.com

Germany: +49 621 776 1111  
fa-info@de.pepperl-fuchs.com

Singapore: +65 6779 9091  
fa-info@sg.pepperl-fuchs.com

**PF** PEPPERL+FUCHS

## Technical Data

<b>Output</b>		
Output type		RS 422, incremental
Load current		max. per channel 20 mA , conditionally short-circuit proof (not with $U_b$ ), reverse polarity protected
Output frequency		max. 200 kHz
Rise time		100 ns
<b>Connection</b>		
Cable		Ø6.5 mm, 4 x 2 x 0.14 mm <sup>2</sup> , 1 m
<b>Standard conformity</b>		
Degree of protection		DIN EN 60529, IP54
Climatic testing		DIN EN 60068-2-78 , no moisture condensation
Emitted interference		EN 61000-6-4:2007/A1:2011
Noise immunity		EN 61000-6-2:2005
Shock resistance		DIN EN 60068-2-27, 100 g, 3 ms
Vibration resistance		DIN EN 60068-2-6, 10 g, 10 ... 2000 Hz
<b>Approvals and certificates</b>		
UL approval		cULus Listed, General Purpose, Class 2 Power Source
<b>Ambient conditions</b>		
Operating temperature		-5 ... 80 °C (23 ... 176 °F) , movable cable -20 ... 80 °C (-4 ... 176 °F), fixed cable
Storage temperature		-40 ... 85 °C (-40 ... 185 °F)
<b>Mechanical specifications</b>		
Material		
Housing		powder coated aluminum
Flange		3.1645 aluminum
Shaft		Stainless steel 1.4305 / AISI 303
Mass		approx. 290 g
Rotational speed		max. 6000 min <sup>-1</sup>
Moment of inertia		≤ 40 gcm <sup>2</sup>
Starting torque		≤ 1.5 Ncm
Shaft load		
Angle offset		1 °
Axial offset		max. 1 mm

**Connection**

Signal	Cable
GND	White
U <sub>b</sub>	Brown
A	Green
B	Grey
$\bar{A}$	Yellow
$\bar{B}$	Pink
0	Blue
$\bar{0}$	Red
U <sub>b</sub> Sens <sup>*)</sup>	Violet <sup>*)</sup>
GND Sens <sup>*)</sup>	Black <sup>*)</sup>
Screen	-

<sup>\*)</sup> only for devices with 5 V supply and RS 422 interface

**Operation**

**Signal outputs**

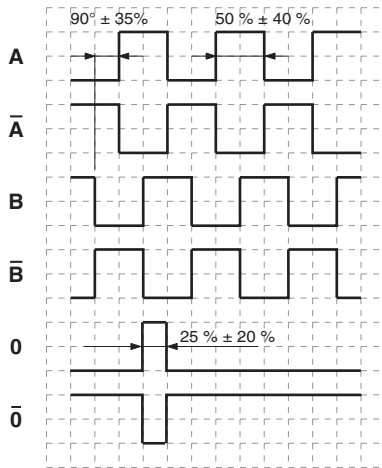

↻ cw - with view onto the shaft clamping ring

**Type Code**

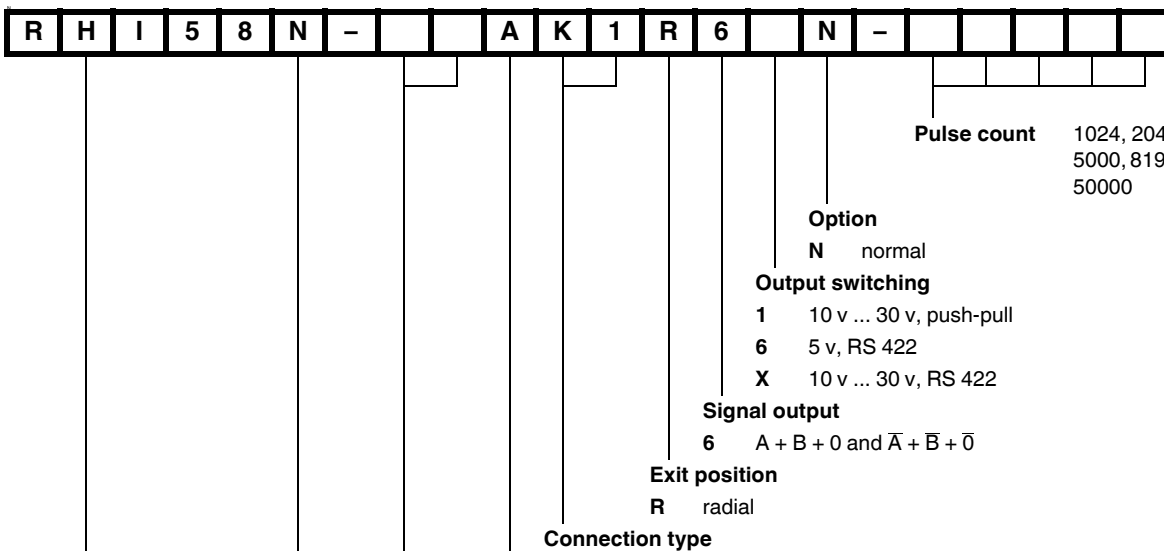

Release date: 2022-12-12 Date of issue: 2022-12-12 Filename: t151831\_eng.pdf

Refer to "General Notes Relating to Pepperl+Fuchs Product Information".

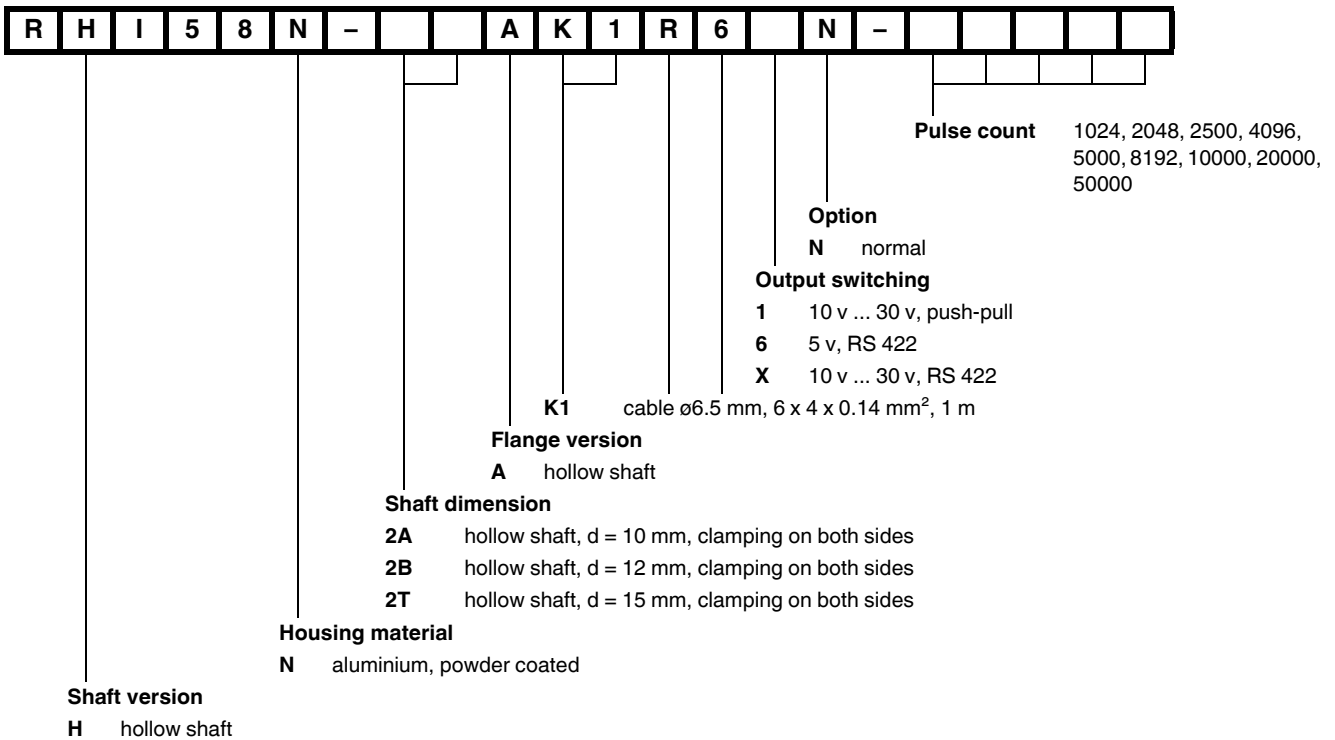

## Installation

### Anti-interference measures

The use of highly sophisticated microelectronics requires a consistently implemented anti-interference and wiring concept. This becomes all the more important the more compact the constructions are and the higher the demands are on the performance of modern machines.

The following installation instructions and proposals apply for "normal industrial environments". There is no ideal solution for all interfering environments.

When the following measures are applied, the encoder should be in perfect working order:

- Termination of the serial line with a 120 Ω resistor (between Receive/Transmit and Receive/Transmit) at the beginning and end of the serial line (e. g. the control and the last encoder).
- The wiring of the encoder should be laid at a large distance to energy lines which could cause interferences.
- Cable cross-section of the screen at least 4 mm<sup>2</sup>.
- Cable cross-section at least 0,14 mm<sup>2</sup>.
- The wiring of the screen and 0 V should be arranged radially, if and when possible.
- Do not kink or jam the cables.
- Adhere to the minimum bending radius as given in the data sheet and avoid tensile as well as shearing load.

### Operating instructions

Every encoder manufactured by Pepperl+Fuchs leaves the factory in a perfect condition. In order to ensure this quality as well as a faultless operation, the following specifications have to be taken into consideration:

- Avoid any impact on the housing and in particular on the encoder shaft as well as the axial and radial overload of the encoder shaft.
- The accuracy and service life of the encoder is guaranteed only, if a suitable coupling is used.
- The operating voltage for the encoder and the follow-up device (e. g. control) has to be switched on and off simultaneously.
- Any wiring work has to be carried out with the system in a dead condition.
- The maximum operating voltages must not be exceeded. The devices have to be operated at extra-low safety voltage.

### Notes on connecting the electric screening

The immunity to interference of a plant depends on the correct screening. In this field installation faults occur frequently. Often the screen is applied to one side only, and is then soldered to the earthing terminal with a wire, which is a valid procedure in LF engineering. However, in case of EMC the rules of HF engineering apply.

One basic goal in HF engineering is to pass the HF energy to earth at an impedance as low as possible as otherwise energy would discharge into the cable. A low impedance is achieved by a large-surface connection to metal surfaces.

The following instructions have to be observed:

- Apply the screen on both sides to a "common earth" in a large surface, if there is no risk of equipotential currents.
- The screen has to be passed behind the insulation and has to be clamped on a large surface below the tension relief.
- In case of cable connections to screw-type terminals, the tension relief has to be connected to an earthed surface.
- If plugs are used, metallised plugs only should be fitted (such as sub D plugs with metallised housing). Please observe the direct connection of the tension relief to the housing.

<p>Advantage: shield</p> <p>relief</p> <p>Disadvantage:</p>	<p>metallised connector, clamped with the strain clamp</p> <p>soldering shield on</p>
---	---



**Safety instructions**

Please observe the national safety and accident prevention regulations as well as the subsequent safety instructions in these operating instructions when working on encoders.  
 If failures cannot be remedied, the device has to be shut down and has to be secured against accidental operation.  
 Repairs may be carried out only by the manufacturer. Entry into and modifications of the device are not permissible.  
 Tighten the clamping ring only, if a shaft has been fitted in the area of the clamping ring (hollow shaft encoders).  
 Tighten all screws and plug connectors prior to operating the encoder.

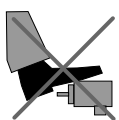

Do not stand on the encoder!



Do not remachine the drive shaft!



Avoid impact!



Do not remachine the housing!

Release date: 2022-12-12 Date of issue: 2022-12-12 Filename: t151831\_eng.pdf