

Singleturn absolute rotary encoder CVS78E



- Up to 16 Bit singleturn
- ATEX approval
- IECEx approval
- Flameproof enclosure
- Removable connection cap



Function

Absolute encoders deliver an absolute step value for each angle setting. All these values are represented by code samples on one or more code disks which are sampled by a photoelectric array.

The absolute encoder has a maximum basic resolution of 65536 steps per revolution (16 Bits).

The integrated CAN bus interface of the absolute encoder supports all DeviceNet functions. The following operating modes can be programmed, and can selectively be turned on or off:

- Polled mode
- Cyclic mode
- Sync mode

The device is designed for shaft mounting and is available in servo flange or clamping flange design.

The bus electronics module is integrated into the removable housing cover. This makes it possible to mount or replace the new rotary encoders and the matching bus electronics separately during installation or service.

Dimensions

Encoder length L

Version		Length L
Radial cable exit	Clamping flange	109 mm
	Servo flange	109 mm
Axial cable exit	Clamping flange	125 mm
	Servo flange	125 mm

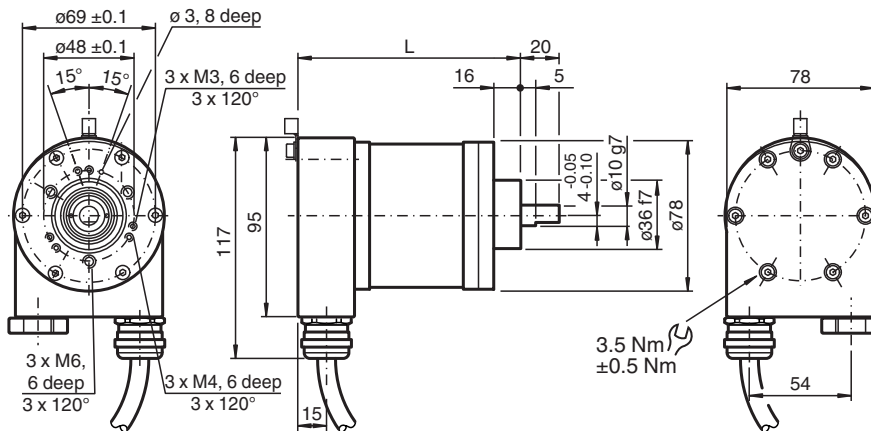

Clamping flange, cable exit radial

Release date: 2024-03-11 Date of issue: 2024-03-11 Filename: t160344_eng.pdf

Refer to "General Notes Relating to Pepperl+Fuchs Product Information".

Pepperl+Fuchs Group
www.pepperl-fuchs.com

USA: +1 330 486 0001
fa-info@us.pepperl-fuchs.com

Germany: +49 621 776 1111
fa-info@de.pepperl-fuchs.com

Singapore: +65 6779 9091
fa-info@sg.pepperl-fuchs.com

PF PEPPERL+FUCHS

Dimensions

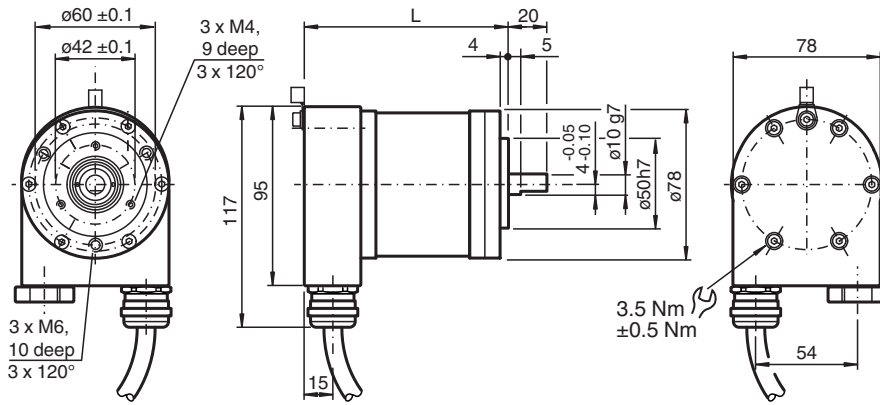

Servo flange, radial cable exit

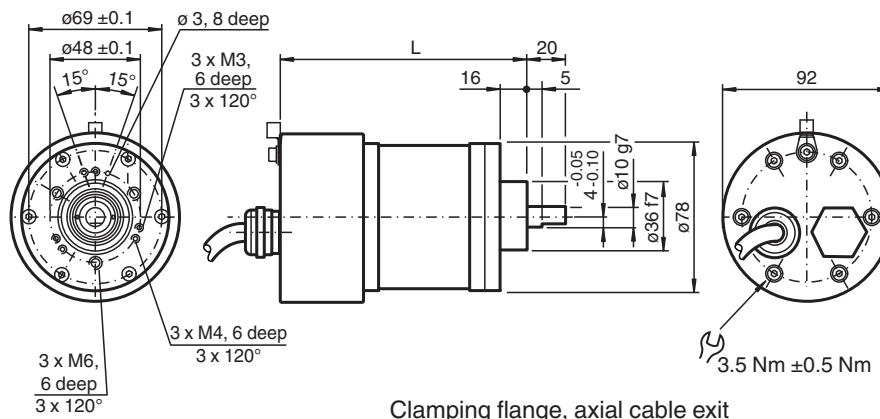

Clamping flange, axial cable exit

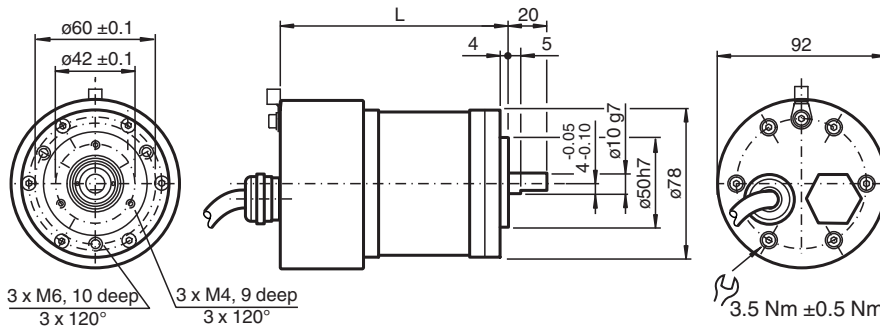

Servo flange, axial cable exit

Shaft 12 mm

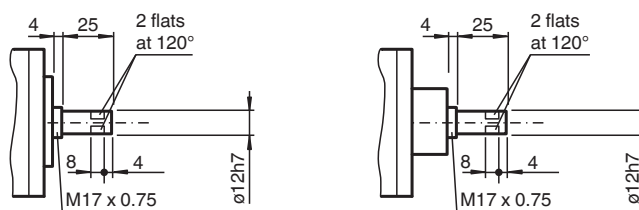

Release date: 2024-03-11 Date of issue: 2024-03-11 Filename: t160344_eng.pdf

Technical Data

General specifications

Refer to "General Notes Relating to Pepperl+Fuchs Product Information".

Pepperl+Fuchs Group
www.pepperl-fuchs.com

USA: +1 330 486 0001
fa-info@us.pepperl-fuchs.com

Germany: +49 621 776 1111
fa-info@de.pepperl-fuchs.com

Singapore: +65 6779 9091
fa-info@sg.pepperl-fuchs.com

Technical Data

Detection type	photoelectric sampling	
Device type	Singleturn absolute rotary encoder	
Functional safety related parameters		
MTTF _d	25 a	
L ₁₀	7.7 E+9 at 3000 rpm	
Electrical specifications		
Operating voltage	U _B	10 ... 30 V DC
No-load supply current	I ₀	max. 350 mA
Linearity	± 2 LSB at 16 Bit, ± 1 LSB at 13 Bit, ± 0,5 LSB at 12 Bit	
Output code	binary code	
Code course (counting direction)	cw ascending (clockwise rotation, code course ascending) cw descending (clockwise rotation, code course descending)	
Interface		
Interface type	CANopen	
Resolution		
Single turn	up to 16 Bit	
Overall resolution	up to 16 Bit	
Transfer rate	max. 1 MBit/s	
Standard conformity	communication profile: DS 301 Device profiles: DS 406 and DS 417 , programmable according to class 2	
Connection		
Cable	Ø 10.2 mm, Radox 9 x 0.5 mm ²	
Terminal compartment	see ordering information	
Standard conformity		
Degree of protection	DIN EN 60529, IP66	
Climatic testing	DIN EN 60068-2-78 , no moisture condensation	
Emitted interference	EN 61000-6-4:2007/A1:2011	
Noise immunity	EN 61000-6-2:2005	
Shock resistance	DIN EN 60068-2-27, 100 g, 3 ms	
Vibration resistance	DIN EN 60068-2-6, 10 g, 10 ... 2000 Hz	
Approvals and certificates		
IECEX approval		
Equipment protection level Gb	IECEX ITS 15.0061X	
ATEX approval		
Equipment protection level Gb	ITS 15 ATEX 18372X	
Ambient conditions		
Operating temperature	-40 ... 70 °C (-40 ... 158 °F)	
Storage temperature	-40 ... 85 °C (-40 ... 185 °F)	
Mechanical specifications		
Material		
Combination 1	housing: anodized aluminum flange: anodized aluminum shaft: Stainless steel 1.4404 / AISI 316L	
Combination 2 (Inox)	housing: Stainless steel 1.4404 / AISI 316L flange: Stainless steel 1.4404 / AISI 316L shaft: Stainless steel 1.4404 / AISI 316L	
Mass	approx. 2600 g (combination 1) approx. 3900 g (combination 2)	
Rotational speed	max. 3000 min ⁻¹	
Moment of inertia	180 gcm ²	
Starting torque	≤ 4 Ncm	
Shaft load		
Axial	60 N	
Radial	80 N	
General information		
Use in the hazardous area	see instruction manuals	

Release date: 2024-03-11 Date of issue: 2024-03-11 Filename: t160344_eng.pdf

Refer to "General Notes Relating to Pepperl+Fuchs Product Information".

Pepperl+Fuchs Group
www.pepperl-fuchs.comUSA: +1 330 486 0001
fa-info@us.pepperl-fuchs.comGermany: +49 621 776 1111
fa-info@de.pepperl-fuchs.comSingapore: +65 6779 9091
fa-info@sg.pepperl-fuchs.com

PEPPERL+FUCHS

Connection

Terminal	Cable	Explanation
(-)	1	- Power supply
(+)	2	+ Power supply
L	3	CAN low
H	4	CAN high
G	5	CAN ground
L	6	CAN low
H	7	CAN high
G	8	CAN ground
⊥	green / yellow	Ground connection of encoder housing

Configuration

Indicating and operating elements

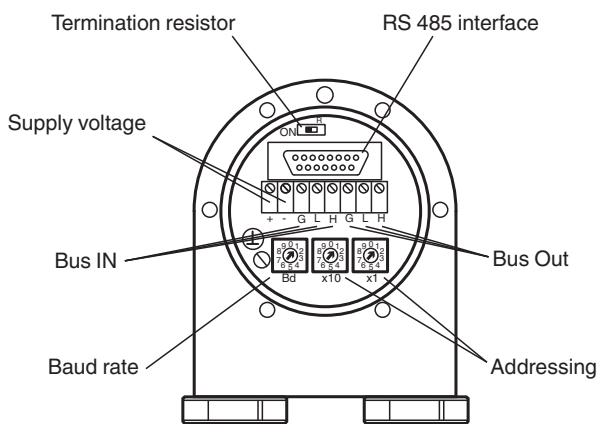

Adjusting the participant address

The participant address can be adjusted with the rotary switches. The address can be defined between 1 and 96, and may only be assigned once. The addresses 97 ... 99 are reserved.

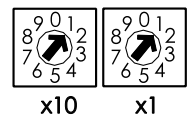

Adjusting the termination resistor

The terminating resistor R_T (121 Ω) can be connected to the circuit by means of the switch:



Baud rate adjustment

Baud rate [kBit/s]	Switch position	Baud rate [kBit/s]	Switch position
20	0	500	5
50	1	800	6
100	2	1000	7
125	3	reserved	8
250	4	set baud rate by SDO message and LSS	9

Parameterization

Programmable CAN operating modes

Mode	Explanation
Polled mode	The connected host requests the current actual position value via a remote transmission request telegram. The absolute encoder reads in the current position, calculates all parameters that have been set and sends back the process actual value through the same CAN identifier.
Cyclic mode	The absolute encoder sends the current actual process value cyclically, without being prompted by the host. The cycle time can be programmed in milliseconds for values between 1 ms and 65536 ms.

Release date: 2024-03-11 Date of issue: 2024-03-11 Filename: t160344_eng.pdf

Refer to "General Notes Relating to Pepperl+Fuchs Product Information".

Sync mode	After the sync telegram has been received by the host, the absolute encoder sends the current actual process value. If multiple nodes should respond to the sync telegram, the individual nodes report one after the other according to their CAN identifier. There is no programming of an offset time. The sync counter can be programmed so that the rotary encoder does not transmit until after a defined number of sync telegrams.
-----------	--

Programmable rotary encoder parameters

Parameter	Explanation
Operating parameter	The direction of rotation (complement) can be specified by parameter as the operating parameter. This parameter determines the direction of rotation in which the output code will ascend or descend.
Resolution per revolution	The "Resolution" parameter is used to program the rotary encoder so that a desired number of steps can be implemented in reference to one revolution.
Preset value	The preset value is the desired position value that must be achieved for a specific physical setting of the axis. The preset value parameter is used to set the actual position value to the desired actual process value.
2 limit switches	A total of two positions can be programmed. The absolute encoder sets one bit to high state in the 32 Bit actual process value if a value falls outside the range between these two positions.
8 cam switches	Up to 8 position values can be programmed as cams. By reaching these values bits in object 6300h Cam state register are set.

Type Code

Ordering information

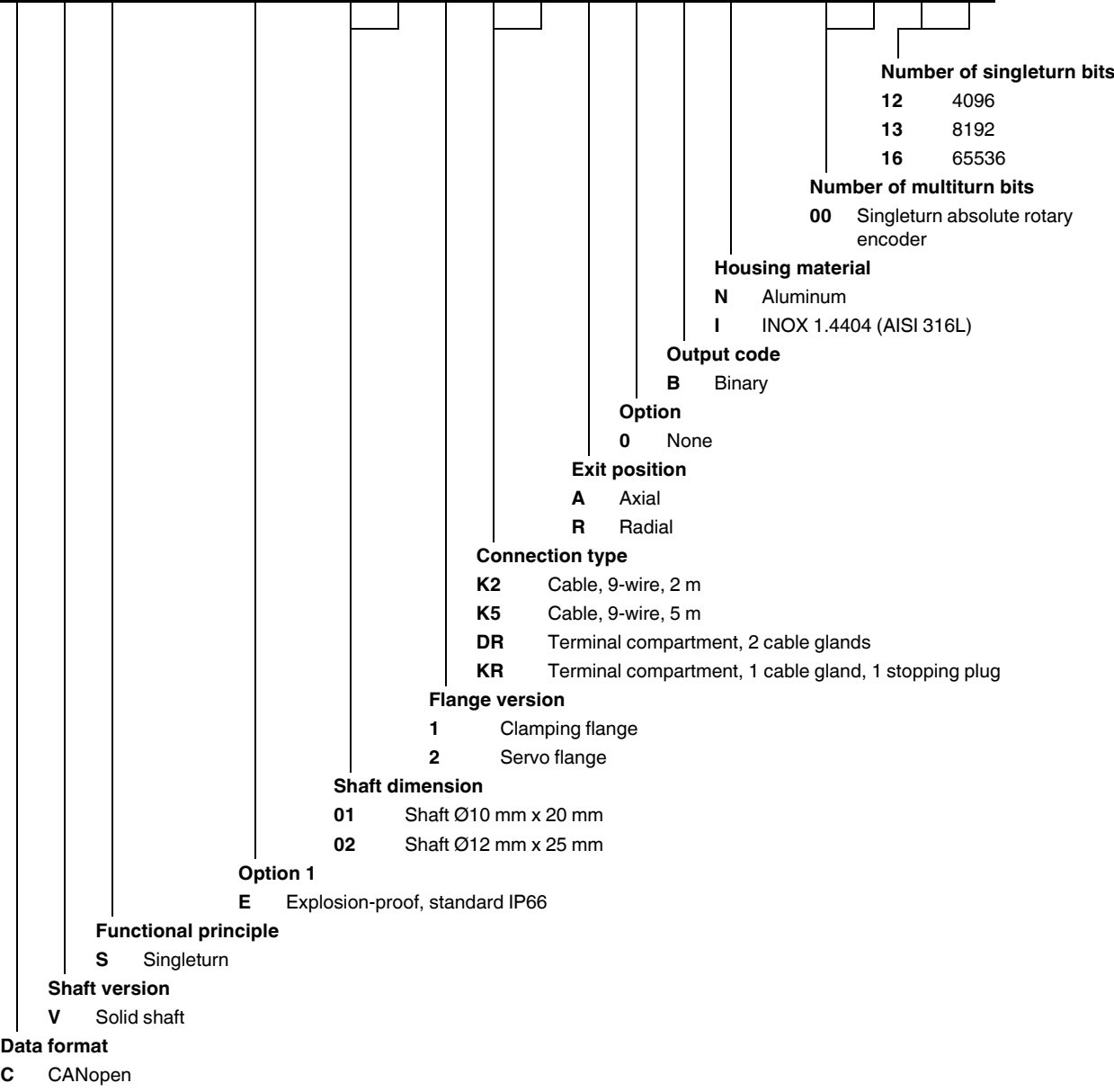

Release date: 2024-03-11 Date of issue: 2024-03-11 Filename: t160344_eng.pdf

Installation

Anti-interference measures

The use of highly sophisticated microelectronics requires a consistently implemented anti-interference and wiring concept. This becomes all the more important the more compact the constructions are and the higher the demands are on the performance of modern machines.

The following installation instructions and proposals apply for "normal industrial environments". There is no ideal solution for all interfering environments.

When the following measures are applied, the encoder should be in perfect working order:

- Termination of the serial line with a 120 Ω resistor (between Receive/Transmit and Receive/Transmit) at the beginning and end of the serial line (e. g. the control and the last encoder).
- The wiring of the encoder should be laid at a large distance to energy lines which could cause interferences.
- Cable cross-section of the screen at least 4 mm².
- Cable cross-section at least 0,14 mm².
- The wiring of the screen and 0 V should be arranged radially, if and when possible.
- Do not kink or jam the cables.
- Adhere to the minimum bending radius as given in the data sheet and avoid tensile as well as shearing load.

Operating instructions

Every encoder manufactured by Pepperl+Fuchs leaves the factory in a perfect condition. In order to ensure this quality as well as a faultless operation, the following specifications have to be taken into consideration:

- Avoid any impact on the housing and in particular on the encoder shaft as well as the axial and radial overload of the encoder shaft.
- The accuracy and service life of the encoder is guaranteed only, if a suitable coupling is used.
- The operating voltage for the encoder and the follow-up device (e. g. control) has to be switched on and off simultaneously.
- Any wiring work has to be carried out with the system in a dead condition.
- The maximum operating voltages must not be exceeded. The devices have to be operated at extra-low safety voltage.

Notes on connecting the electric screening

The immunity to interference of a plant depends on the correct screening. In this field installation faults occur frequently. Often the screen is applied to one side only, and is then soldered to the earthing terminal with a wire, which is a valid procedure in LF engineering. However, in case of EMC the rules of HF engineering apply.

One basic goal in HF engineering is to pass the HF energy to earth at an impedance as low as possible as otherwise energy would discharge into the cable. A low impedance is achieved by a large-surface connection to metal surfaces.

The following instructions have to be observed:

- Apply the screen on both sides to a "common earth" in a large surface, if there is no risk of equipotential currents.
- The screen has to be passed behind the insulation and has to be clamped on a large surface below the tension relief.
- In case of cable connections to screw-type terminals, the tension relief has to be connected to an earthed surface.
- If plugs are used, metallised plugs only should be fitted (such as sub D plugs with metallised housing). Please observe the direct connection of the tension relief to the housing.

Advantage:	metallised connector, shield
	clamped with the strain relief
	clamp
Disadvantage:	soldering shield on

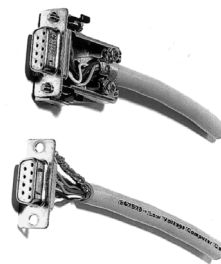

Safety instructions

Please observe the national safety and accident prevention regulations as well as the subsequent safety instructions in these operating instructions when working on encoders.

If failures cannot be remedied, the device has to be shut down and has to be secured against accidental operation.

Repairs may be carried out only by the manufacturer. Entry into and modifications of the device are not permissible.

Tighten the clamping ring only, if a shaft has been fitted in the area of the clamping ring (hollow shaft encoders).

Tighten all screws and plug connectors prior to operating the encoder.

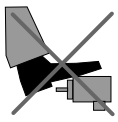

Do not stand on the encoder!

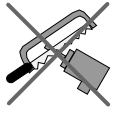

Do not remachine the drive shaft!



Avoid impact!



Do not remachine the housing!