

# Multiturn absolute encoder

## UVM36M-\*\*\*\*\*

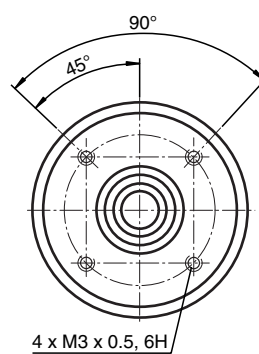

- Very small housing
- High climatic resistance
- 4 Bit multiturn
- Analog output
- Surge and reverse polarity protection

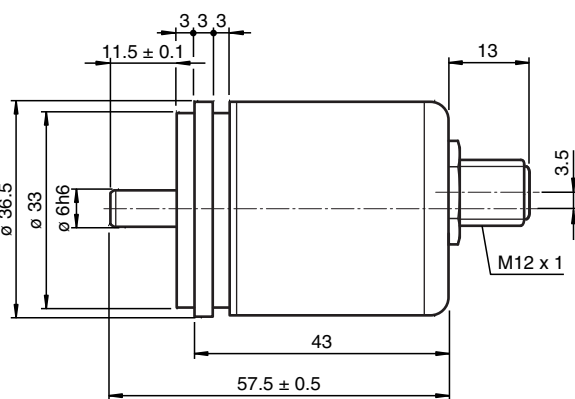
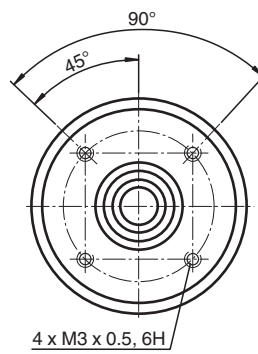
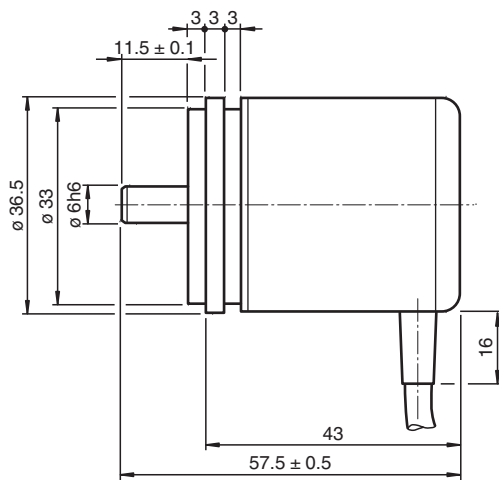

Release date: 2022-04-21 Date of issue: 2022-12-12 Filename: t161990\_eng.pdf

Refer to "General Notes Relating to Pepperl+Fuchs Product Information".

Pepperl+Fuchs Group  
www.pepperl-fuchs.com

USA: +1 330 486 0001  
fa-info@us.pepperl-fuchs.com

Germany: +49 621 776 1111  
fa-info@de.pepperl-fuchs.com

Singapore: +65 6779 9091  
fa-info@sg.pepperl-fuchs.com

**PF** PEPPERL+FUCHS

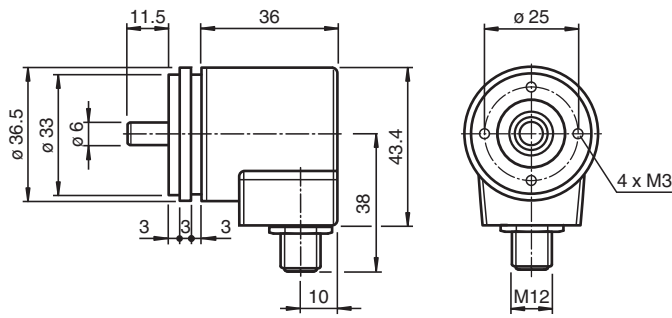

## Technical Data

### General specifications

Detection type	magnetic sampling	
Device type	Multiturn absolute encoder	
Measurement range	min. 0 ... 22.5 ° max. 16 x 360 °	
Resolution	16 Bit (12 bits/revolution)	

### Electrical specifications

Operating voltage	U <sub>B</sub>	12 ... 30 V DC , PELV
Current consumption	typ. 15 mA	

### Input 1

Input type	lower limit of measurement range	
Signal voltage		
High	12 ... 30 V DC	
Signal duration	min. 1 s	

### Input 2

Input type	upper limit of measurement range	
Signal voltage		
High	12 ... 30 V DC	
Signal duration	min. 1 s	

### Analog output

Output type	1 analog output, voltage	
Default setting	rising ramp at ccw rotation	
Linearity error	≤ 0.15 %	
Load resistor	min. 10000 Ω ; Max. value for supply voltage 12 V. For higher supply voltage lower load resistance can be used.	

### Connection

Connector	M12 connector, 5 pin	
Cable	Ø6 mm, 4 x 2 x 0.14 mm <sup>2</sup> , 1 m	

### Standard conformity

Degree of protection	acc. DIN EN 60529	
Connection side	cable models: IP54 connector models: IP65	
Shaft side	IP65	
Climatic testing	DIN EN 60068-2-3, no moisture condensation	
Emitted interference	EN 61000-6-4:2007	
Noise immunity	EN 61000-6-2:2005	
Shock resistance	DIN EN 60068-2-27, 100 g, 6 ms	
Vibration resistance	DIN EN 60068-2-6, 10 g, 10 ... 1000 Hz	

### Ambient conditions

Release date: 2022-04-21 Date of issue: 2022-12-12 Filename: t161990\_eng.pdf

Refer to "General Notes Relating to Pepperl+Fuchs Product Information".

Pepperl+Fuchs Group  
www.pepperl-fuchs.com

USA: +1 330 486 0001  
fa-info@us.pepperl-fuchs.com

Germany: +49 621 776 1111  
fa-info@de.pepperl-fuchs.com





Singapore: +65 6779 9091  
fa-info@sg.pepperl-fuchs.com

 PEPPERL+FUCHS

## Technical Data

Operating temperature		cable, flexing: -5 ... 70 °C (-23 ... 158 °F), cable, fixed: -30 ... 70 °C (-22 ... 158 °F) connector models: -40 ... 85 °C (-40 ... 185 °F)
Storage temperature		cable models: -30 ... 70 °C (-22 ... 158 °F) connector models: -30 ... 85 °C (-22 ... 185 °F)
Relative humidity		98 % , no moisture condensation
<b>Mechanical specifications</b>		
Material		
Housing		nickel-plated steel
Flange		Aluminum
Shaft		Stainless steel
Mass		approx. 150 g , with cable
Rotational speed		max. 12000 min <sup>-1</sup>
Moment of inertia		30 gcm <sup>2</sup>
Starting torque		< 3 Ncm
Shaft load		
Axial		20 N
Radial		40 N

## Accessories

	<b>9108, 6</b>	Measuring wheel
	<b>9109, 6</b>	Measuring wheel for shaft diameter 6 mm
	<b>9110, 6</b>	Measuring wheel for shaft diameter 6 mm
	<b>9113, 6</b>	Measuring wheel for shaft diameter 6 mm

## Function

This absolute encoder with internal magnetic sampling provides an analog output. The output voltage value is corresponding to the shaft setting .

The encoder can be easily programmed by means of electrical inputs and pushbuttons.

## Connection

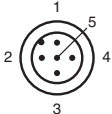
Signal	Wire end	M12 connector
Analog output	Green	1
+V <sub>s</sub> (encoder)	Red	2
GND (encoder)	Yellow	3
Set 2	White	4
Set 1	Brown	5
Shielding	Screen	Housing
Pinout	-	

## Additional Information

### Description of rotary encoder functions

#### Default Settings

	Lower measuring range limit	Mid measuring range	Upper measuring range limit
Singleturn absolute rotary encoder	0	180°	360°
Multiturn absolute rotary encoder	0	8 x 360°	16 x 360°

### Programming Encoders with No Operating Buttons

#### Scaling the measuring range

Use signal inputs "Set 1" and "Set 2" to scale the measuring range (minimum measuring range: 22.5°).

1. Connect signal inputs "Set 1" and "Set 2" simultaneously to +U<sub>B</sub> for 15 seconds. The programming mode is activated now.
2. Turn the rotary encoder shaft to position 1 (lower measuring range limit).
3. Connect signal input "Set 1" to a high-potential source ( $12 \text{ VDC} \leq \text{high potential} \leq +U_B$ ) for 1 second.
4. Connect signal input "Set 1" to ground
5. Turn the rotary encoder shaft to position 2 (upper measuring range limit).
6. Connect signal input "Set 2" to a high-potential source ( $12 \text{ VDC} \leq \text{high potential} \leq +U_B$ ) for 1 second.
7. Connect signal input "Set 2" to ground

The analog output is now scaled to the programmed measuring range and the rotary encoder will operate in normal mode.

#### Resetting to the Default Setting

1. Connect the two signal inputs ("Set 1" and "Set 2") to a high-potential source ( $12 \text{ VDC} \leq \text{high potential} \leq +U_B$ ) for 1 second. The measuring range is then reset to the default setting.

### Programming Encoders with Operating Buttons

#### Scaling the measuring range

Use operating buttons "Lim1" and "Lim2" to scale the measuring range (minimum measuring range: 22.5°).

1. Press the two operating buttons ("Lim1" and "Lim2") simultaneously. Both LEDs will light up. Press and hold the operating buttons for 15 seconds until the two LEDs start to flash. The rotary encoder is now in programming mode.
2. Turn the rotary encoder shaft to position 1 (lower measuring range limit).
3. Press and hold operating button "Lim1" for 1 second. The green LED will now light up permanently.
4. Turn the rotary encoder shaft to position 2 (upper measuring range limit).
5. Press and hold operating button "Lim2" for 1 second.

The analog output is now scaled to the programmed measuring range and the rotary encoder will operate in normal mode. Only the green LED will light up.

#### Resetting to the Default Setting

1. Press the two operating buttons ("Lim1" and "Lim2") simultaneously. Both LEDs will light up. Press and hold the operating buttons for 30 seconds. After 15 seconds, the two LEDs will start to flash.

When the green LED goes out and the yellow LED lights up permanently, the measuring range is reset to the default setting.

**Status LEDs**

The rotary encoder is equipped with two status LEDs. These LEDs have three possible states: off, flashing, or on. The LEDs use different combinations of these states to indicate the status of the rotary encoder.

Yellow LED	Green LED	Description
On	Off	Rotary encoder operation using default settings
Off	On	Rotary encoder operation using scaled measuring range (customer-specific setting)
On	On	Programming mode initiated (temporary state)
Flashes	Flashes	Rotary encoder in programming mode
On	Flashes	Position 2 set, waiting for position 1
Flashes	On	Position 1 set, waiting for position 2

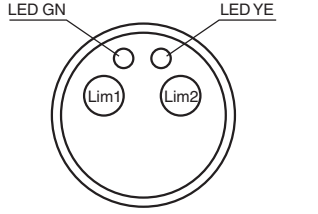

**Analog Output Properties**

Depending on its design, the rotary encoder projects the current angular position of the rotary encoder shaft in an analog current or voltage value. The following graphic shows the values the output accepts at the various angular positions:

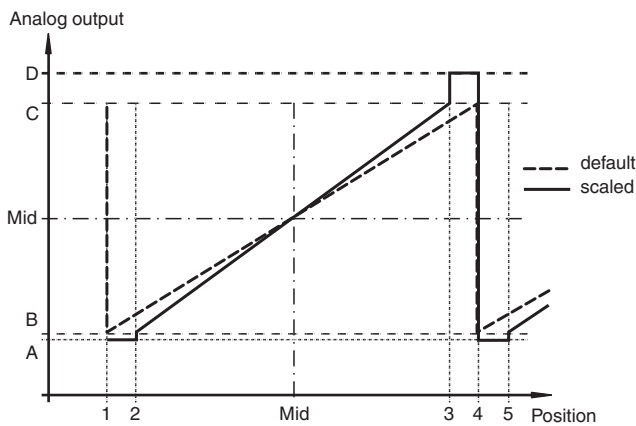

Legend:

Encoder type <sup>1)</sup>		Angular position					
		1	2	Mid	3	4	5
Singleturn	Factory default setting	0°	-	180°	-	360°	-
	Scaled	0°	Lower measuring range limit	-	Upper measuring range limit	360°	Lower measuring range limit
Multiturn	Factory default setting	0°	-	2 <sup>4</sup> x 180°	-	2 <sup>4</sup> x 360°	-
	Scaled <sup>2)</sup>	0°	Lower measuring range limit	-	Upper measuring range limit	2 <sup>n</sup> x 360°	Lower measuring range limit

n = whole number from 1 to 16

1) See model number

2) Overflow at 360°, 720°, 1440°, 2880°, 5760°, etc. depending on the scale set.

Encoder output type	Analog output value				
	A	B	Mid	C	D
0 V ... 5 V	-	0 V	2.5 V	5 V	-
0.5 V ... 4.5 V	0.25 V	0.5 V	2.5 V	4.5 V	4.75 V
0 V ... 10 V	-	0 V	5 V	10 V	-
0.5 V ... 9.5 V	0.25 V	0.5 V	5 V	9.5 V	9.75 V
4 mA ... 20 mA	3.6 mA	4 mA	12 mA	20 mA	22 mA
0 mA ... 20 mA	-	0 mA	10 mA	20 mA	-

Release date: 2022-04-21 Date of issue: 2022-12-12 Filename: t161990\_eng.pdf

## Order code

U	V	M	3	6	M	-	0	3	S							N	-	0	4	1	2
																	Number of bits singleturn				
																	12	4096			
																	Number of bits multiturn				
																	04	16 revolutions			
																	<b>Temperature</b>				
																	N	normal			
																	<b>Output code</b>				
																	1	0 V ... 5 V			
																	2	0 V ... 10 V			
																	3	0.5 V ... 4.5 V			
																	4	0.5 V ... 9.5 V			
																	Option 1				
																	0	none			
																	1	Pushbuttons (only with radial exit)			
																	<b>Exit position</b>				
																	A	Axial			
																	R	Radial			
																	<b>Connection type</b>				
																	K1	Cable Ø6 mm, 4 x 2 x 0.14 mm <sup>2</sup> , 1 m			
																	BD	Connector, M12 x 1, 5 pin			
																	<b>Shaft dimension/flange version</b>				
																	03S	Shaft Ø6 mm x 11.5 mm with servo flange			
																	<b>Sampling principle</b>				
																	M	magnetic			
																	<b>Principle of operation</b>				
																	M	Multiturn			
																	<b>Shaft version</b>				
																	V	Solid shaft			
																	<b>Data format</b>				
																	U	Analog voltage output			

## Installation

## Anti-interference measures

The use of highly sophisticated microelectronics requires a consistently implemented anti-interference and wiring concept. This becomes all the more important the more compact the constructions are and the higher the demands are on the performance of modern machines.

The following installation instructions and proposals apply for "normal industrial environments". There is no ideal solution for all interfering environments.

When the following measures are applied, the encoder should be in perfect working order:

- Termination of the serial line with a 120 Ω resistor (between Receive/Transmit and Receive/Transmit) at the beginning and end of the serial line (e. g. the control and the last encoder).
- The wiring of the encoder should be laid at a large distance to energy lines which could cause interferences.
- Cable cross-section of the screen at least 4 mm<sup>2</sup>.
- Cable cross-section at least 0,14 mm<sup>2</sup>.
- The wiring of the screen and 0 V should be arranged radially, if and when possible.
- Do not kink or jam the cables.
- Adhere to the minimum bending radius as given in the data sheet and avoid tensile as well as shearing load.

## Operating instructions

Every encoder manufactured by Pepperl+Fuchs leaves the factory in a perfect condition. In order to ensure this quality as well as a faultless operation, the following specifications have to be taken into consideration:

- Avoid any impact on the housing and in particular on the encoder shaft as well as the axial and radial overload of the encoder shaft.
- The accuracy and service life of the encoder is guaranteed only, if a suitable coupling is used.

- The operating voltage for the encoder and the follow-up device (e. g. control) has to be switched on and off simultaneously.
- Any wiring work has to be carried out with the system in a dead condition.
- The maximum operating voltages must not be exceeded. The devices have to be operated at extra-low safety voltage.

**Notes on connecting the electric screening**

The immunity to interference of a plant depends on the correct screening. In this field installation faults occur frequently. Often the screen is applied to one side only, and is then soldered to the earthing terminal with a wire, which is a valid procedure in LF engineering. However, in case of EMC the rules of HF engineering apply.

One basic goal in HF engineering is to pass the HF energy to earth at an impedance as low as possible as otherwise energy would discharge into the cable. A low impedance is achieved by a large-surface connection to metal surfaces.

The following instructions have to be observed:

- Apply the screen on both sides to a "common earth" in a large surface, if there is no risk of equipotential currents.
- The screen has to be passed behind the insulation and has to be clamped on a large surface below the tension relief.
- In case of cable connections to screw-type terminals, the tension relief has to be connected to an earthed surface.
- If plugs are used, metallised plugs only should be fitted (such as sub D plugs with metallised housing). Please observe the direct connection of the tension relief to the housing.

Advantage: metalised connector,  
shield  
clamped with the strain  
relief  
clamp

Disadvantage: soldering shield on

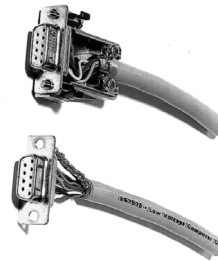

**Safety instructions**

Please observe the national safety and accident prevention regulations as well as the subsequent safety instructions in these operating instructions when working on encoders.

If failures cannot be remedied, the device has to be shut down and has to be secured against accidental operation.

Repairs may be carried out only by the manufacturer. Entry into and modifications of the device are not permissible.

Tighten the clamping ring only, if a shaft has been fitted in the area of the clamping ring (hollow shaft encoders).

Tighten all screws and plug connectors prior to operating the encoder.

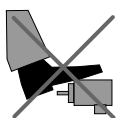

Do not stand on the encoder!



Do not remachine the drive shaft!

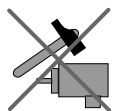

Avoid impact!



Do not remachine the housing!

Release date: 2022-04-21 Date of issue: 2022-12-12 Filename: t161990\_eng.pdf