

Multiturn absolute encoder

JVM42H



- Sturdy construction
- Highly shock / vibration and soiling resistant
- Increased shaft load capacity
- CAN bus with SAE J1939 protocol
- Stainless steel housing
- IP69K
- Very small housing

Heavy-duty encoder



Dimensions

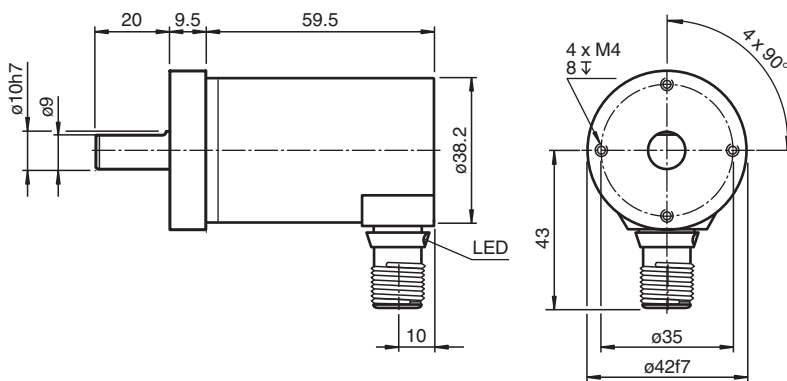
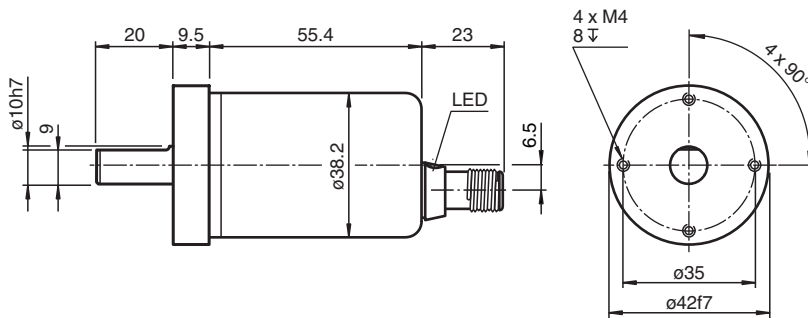

Release date: 2022-04-21 Date of issue: 2022-12-12 Filename: t168182_eng.pdf

Refer to "General Notes Relating to Pepperl+Fuchs Product Information".

Pepperl+Fuchs Group
www.pepperl-fuchs.com

USA: +1 330 486 0001
fa-info@us.pepperl-fuchs.com

Germany: +49 621 776 1111
fa-info@de.pepperl-fuchs.com

Singapore: +65 6779 9091
fa-info@sg.pepperl-fuchs.com

PEPPERL+FUCHS

Dimensions

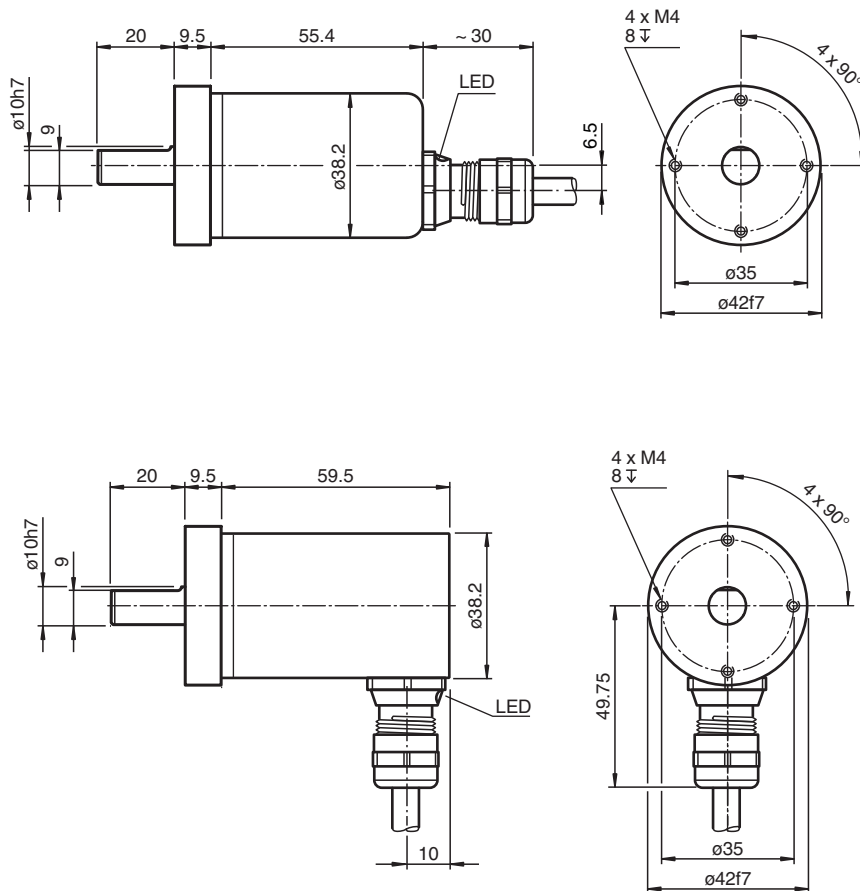

Technical Data

General specifications	
Detection type	magnetic sampling
Device type	Multiturn absolute encoder
Nominal ratings	
Linearity error	$\pm 0.36^\circ$
Indicators/operating means	
LED green	Power on
Electrical specifications	
Operating voltage	U_B 10 ... 30 V DC
Output code	binary code
Code course (counting direction)	adjustable
Interface	
Interface type	J1939
Resolution	
Single turn	12 Bit
Multiturn	up to 15 Bit
Overall resolution	up to 27 Bit
Transfer rate	250 kBit/s
Cycle time	500 μ s
Standard conformity	ISO 11898
Connection	
Connector	M12 connector, 5 pin

Release date: 2022-04-21 | Date of issue: 2022-12-12 | Filename: t168182_eng.pdf

Refer to "General Notes Relating to Pepperl+Fuchs Product Information".

Pepperl+Fuchs Group
www.pepperl-fuchs.com

USA: +1 330 486 0001
fa-info@us.pepperl-fuchs.com

Germany: +49 621 776 1111
fa-info@de.pepperl-fuchs.com



Singapore: +65 6779 9091
fa-info@sg.pepperl-fuchs.com

 PEPPERL+FUCHS

Technical Data

Cable		2 m fixed cable , 5-wire , screened
Standard conformity		
Degree of protection		IEC/EN 60529
Climatic testing		DIN EN 60068-2-3 , 95 % , no moisture condensation
Emitted interference		EN 61000-6-4:2007
Noise immunity		EN 61000-6-2:2005
Shock resistance		DIN EN 60068-2-27, 300 g, 6 ms
Vibration resistance		DIN EN 60068-2-6, 30 g, 55 ... 2000 Hz
Ambient conditions		
Operating temperature		-40 ... 85 °C (-40 ... 185 °F)
Storage temperature		-40 ... 85 °C (-40 ... 185 °F)
Relative humidity		98 % , no moisture condensation
Mechanical specifications		
Flange		servo flange 42 mm with 4 x Threading M4
Shaft dimensions	Ø x l	10 mm x 20 mm
Degree of protection		IP65 / IP67 / IP68 / IP69k
Material		
Housing		stainless steel 1.4404 / AISI 316L
Flange		stainless steel 1.4404 / AISI 316L
Shaft		Stainless steel 1.4412 / AISI 440B
Mass		approx. 350 g
Rotational speed		max. 6000 min ⁻¹
Moment of inertia		30 gcm ²
Starting torque		< 5 Ncm
Shaft load		
Axial		270 N
Radial		270 N

Accessories

	V15S-TEE-V15	T-Splitter M12 socket to M12 plug / M12 socket 5-pin A-coded
	V15S-YEE-V15	Y-Splitter M12 socket to M12 plug / M12 socket 5-pin A-coded

Function

This absolute rotary encoder provides a position value corresponding to the shaft position on its integrated J1939 interface. The rugged miniature encoders are based on magnetic sampling.

Connection

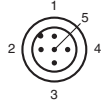
Signal	Wire end	5-pin, M12 x 1 connector
CAN GND	green	1
+V _S	red	2
GND	yellow	3
CAN-High	white	4
CAN-Low	brown	5
Shielding	Shielding	Housing
Pinout		

Example of the transmit commands

Command	Identifier	Data	Comments
Read request Direction	18EA2000	01 EF 00 00 00 00 00 00	
Read request Node	18EA2000	08 EF 00 00 00 00 00 00	
Write Direction	00EF2000	01 01 00 00 00 FF FF FF (CCW increase position)	When you change direction it will give you a different positional value. You will then need to set your preset value.
Write PRESET	00EF2000	04 A8 61 00 00 FF FF FF (value 25.000)	The preset value should be received at positional value 18FFAA20.
Write Save	00EF2000	FA 73 61 76 65 FF FF FF	The settings saved in non-volatile memory

If you change the node number, you will need to cycle power (after you save your settings) for the node number to change. Once you cycle power, you will need to enter the new node number in your identifier. You can confirm everything is saved in non-volatile memory by cycling power.

Receive:

18FFAA20: Positional and speed data

18EA2000: Read response

Order code

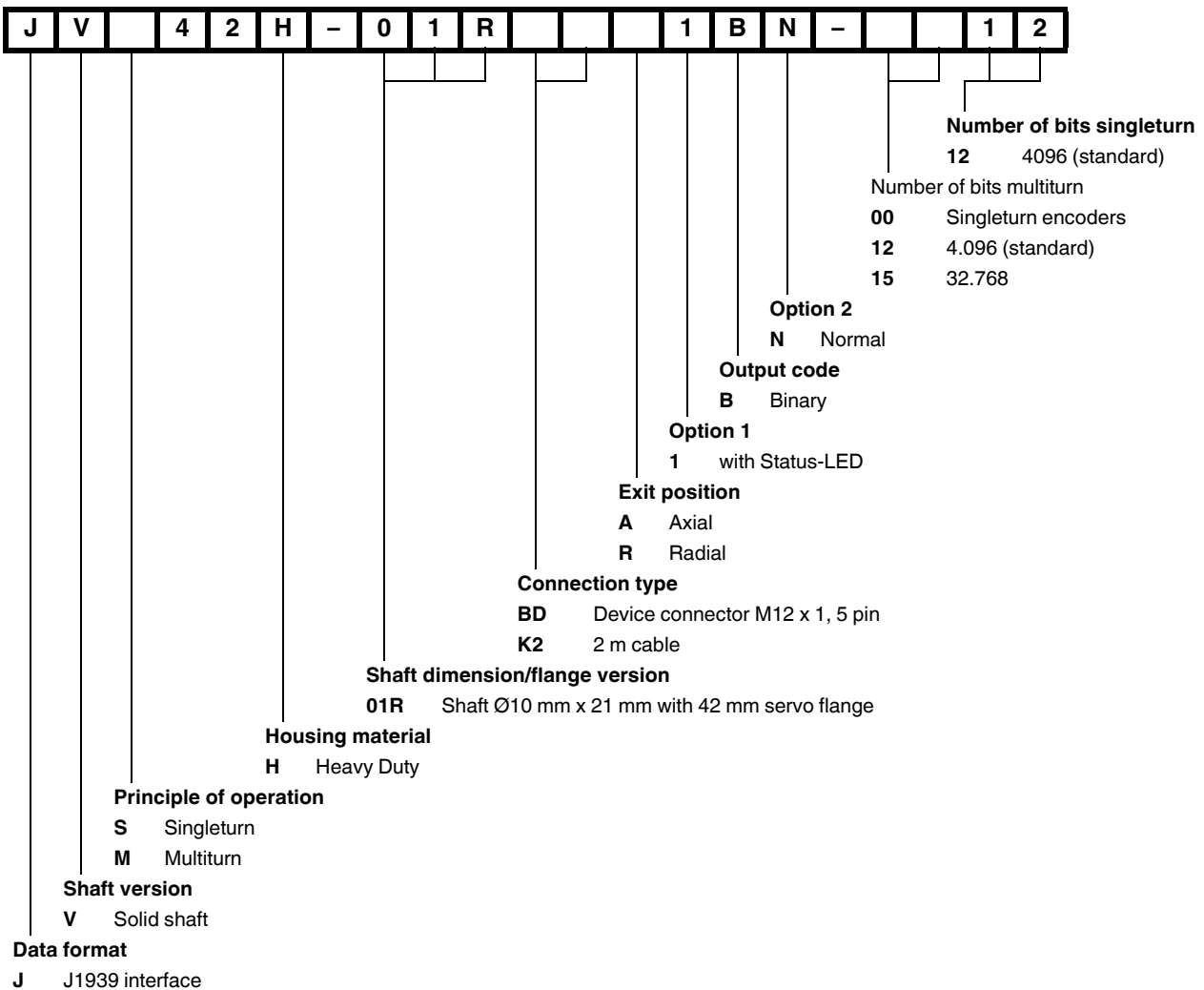

Release date: 2022-04-21 Date of issue: 2022-12-12 Filename: t168182_eng.pdf

Installation

Anti-interference measures

Refer to "General Notes Relating to Pepperl+Fuchs Product Information".

The use of highly sophisticated microelectronics requires a consistently implemented anti-interference and wiring concept. This becomes all the more important the more compact the constructions are and the higher the demands are on the performance of modern machines.

The following installation instructions and proposals apply for "normal industrial environments". There is no ideal solution for all interfering environments.

When the following measures are applied, the encoder should be in perfect working order:

- Termination of the serial line with a 120 Ω resistor (between Receive/Transmit and Receive/Transmit) at the beginning and end of the serial line (e. g. the control and the last encoder).
- The wiring of the encoder should be laid at a large distance to energy lines which could cause interferences.
- Cable cross-section of the screen at least 4 mm².
- Cable cross-section at least 0,14 mm².
- The wiring of the screen and 0 V should be arranged radially, if and when possible.
- Do not kink or jam the cables.
- Adhere to the minimum bending radius as given in the data sheet and avoid tensile as well as shearing load.

Operating instructions

Every encoder manufactured by Pepperl+Fuchs leaves the factory in a perfect condition. In order to ensure this quality as well as a faultless operation, the following specifications have to be taken into consideration:

- Avoid any impact on the housing and in particular on the encoder shaft as well as the axial and radial overload of the encoder shaft.
- The accuracy and service life of the encoder is guaranteed only, if a suitable coupling is used.
- The operating voltage for the encoder and the follow-up device (e. g. control) has to be switched on and off simultaneously.
- Any wiring work has to be carried out with the system in a dead condition.
- The maximum operating voltages must not be exceeded. The devices have to be operated at extra-low safety voltage.

Notes on connecting the electric screening

The immunity to interference of a plant depends on the correct screening. In this field installation faults occur frequently. Often the screen is applied to one side only, and is then soldered to the earthing terminal with a wire, which is a valid procedure in LF engineering. However, in case of EMC the rules of HF engineering apply.

One basic goal in HF engineering is to pass the HF energy to earth at an impedance as low as possible as otherwise energy would discharge into the cable. A low impedance is achieved by a large-surface connection to metal surfaces.

The following instructions have to be observed:

- Apply the screen on both sides to a "common earth" in a large surface, if there is no risk of equipotential currents.
- The screen has to be passed behind the insulation and has to be clamped on a large surface below the tension relief.
- In case of cable connections to screw-type terminals, the tension relief has to be connected to an earthed surface.
- If plugs are used, metallised plugs only should be fitted (such as sub D plugs with metallised housing). Please observe the direct connection of the tension relief to the housing.

Advantage:	metallised connector,	
shield	clamped with the strain	
relief	clamp	
Disadvantage:	soldering shield on	

Safety instructions

Please observe the national safety and accident prevention regulations as well as the subsequent safety instructions in these operating instructions when working on encoders.

If failures cannot be remedied, the device has to be shut down and has to be secured against accidental operation.

Repairs may be carried out only by the manufacturer. Entry into and modifications of the device are not permissible.

Tighten the clamping ring only, if a shaft has been fitted in the area of the clamping ring (hollow shaft encoders).

Tighten all screws and plug connectors prior to operating the encoder.

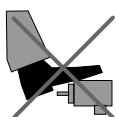

Do not stand on the encoder!

Release date: 2022-04-21 Date of issue: 2022-12-12 Filename: t168182_eng.pdf

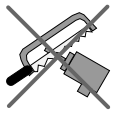

Do not remachine the drive shaft!

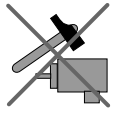

Avoid impact!



Do not remachine the housing!