



Personal Computer - System with Enclosure

VisuNet FLX

PC-320S-^{*}-A-^{*}

- Fully modular design which enables easy migration of individual components
- Large application flexibility due to identical basic components that can be configured as required
- 7th generation Intel Celeron
- Global certifications

Personal Computer - System with Enclosure



Function

The VisuNet FLX Systems are designed for Zone 2/22 (Div.2) and non-Ex applications. The different mounting and configuring options lead to the highest application flexibility. Due to a fully modular design, the new platform, which is geared to the needs of the (petro-) chemical and pharmaceutical industries, the HMIs can be configured to fit exactly and enables simple and fast adjustments in the field. With the modern, compact design less installation space is required. The low weight allows a cost effective and easy installation.

Dimensions

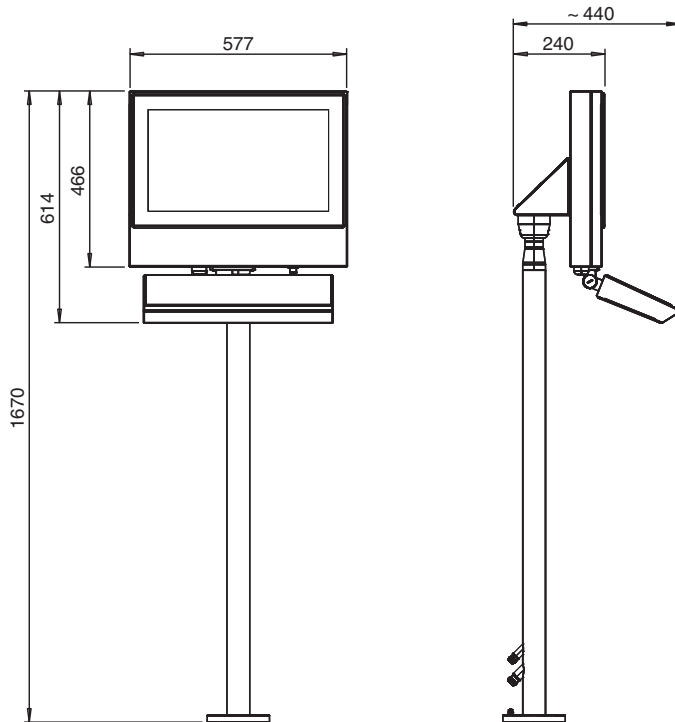

Release date: 2023-11-02 Date of issue: 2023-11-02 Filename: t193552_eng.pdf

Refer to "General Notes Relating to Pepperl+Fuchs Product Information".

Pepperl+Fuchs Group
www.pepperl-fuchs.com

USA: +1 330 486 0002
pa-info@us.pepperl-fuchs.com

Germany: +49 621 776 2222
pa-info@de.pepperl-fuchs.com

Singapore: +65 6779 9091
pa-info@sg.pepperl-fuchs.com

PF PEPPERL+FUCHS

Dimensions

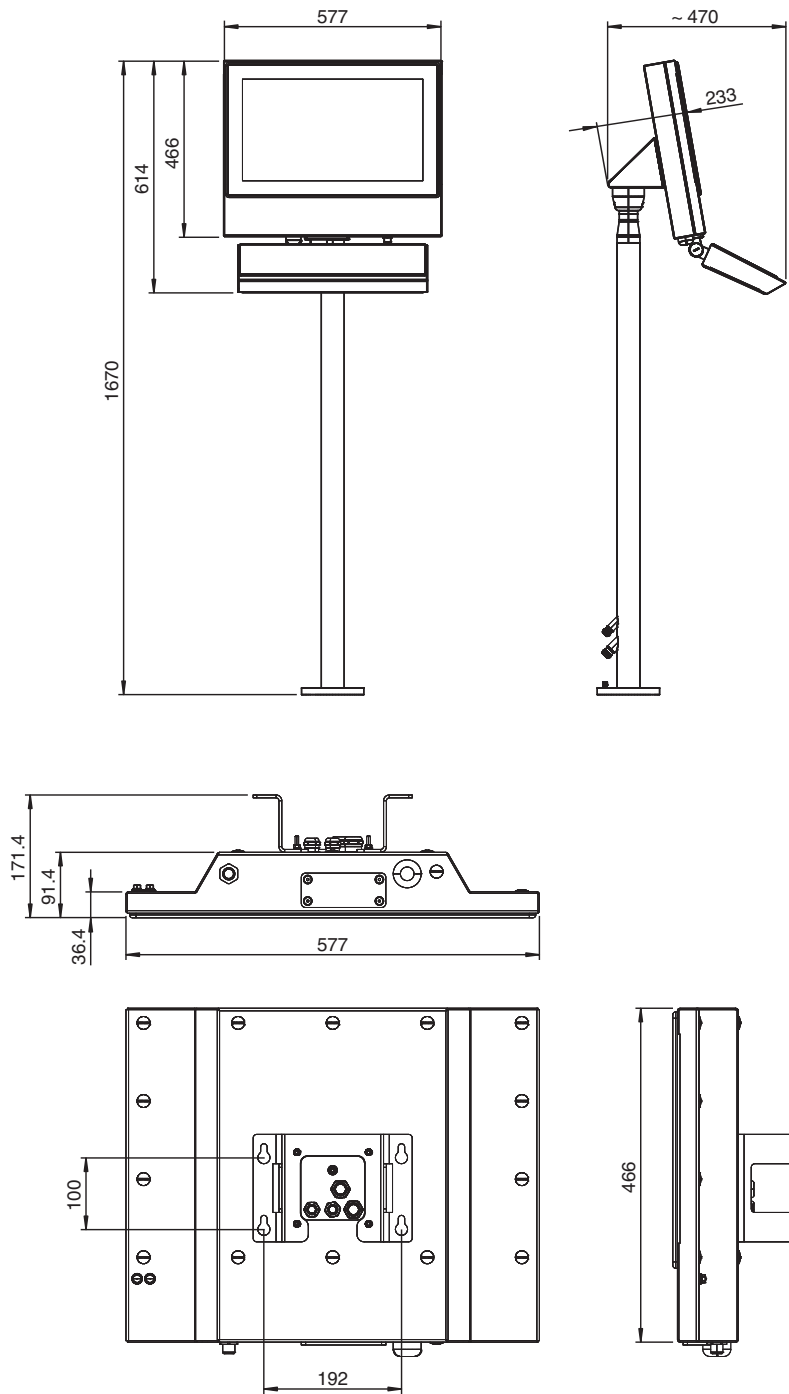

Technical Data

General specifications

Type	Personal Computer
Hardware	
Processor	Intel® Celeron™ 3965U

Release date: 2023-11-02 Date of issue: 2023-11-02 Filename: t193552_eng.pdf

Refer to "General Notes Relating to Pepperl+Fuchs Product Information".

Pepperl+Fuchs Group
www.pepperl-fuchs.com

USA: +1 330 486 0002
pa-info@us.pepperl-fuchs.com

Germany: +49 621 776 2222
pa-info@de.pepperl-fuchs.com

Singapore: +65 6779 9091
pa-info@sg.pepperl-fuchs.com

PF PEPPERL+FUCHS

Technical Data

RAM	2x SO-DIMM slots, supports up to 32 GB DDR4-2133 (one SO-DIMM slot)
	Configurable RAM options: Industrial temperature grade (temperature option A): A: 1x 4GB DDR4-2133 [Celeron] B: 1x 8GB DDR4-2133 C: 1x 16GB DDR4-2133
Mass storage	Storage interface: 1x M.2 2242/2280 M Key, PCIe + SATA 3
	Configurable storage options: Industrial temperature grade (temperature option A): A: 32 GB M.2 SATA 3 [Celeron] D: 256 GB M.2 NVMe 1.3 (PCIe 4x) E: 512 GB M.2 NVMe 1.3 (PCIe 4x)
Supply	
Power consumption	
AC	A: 115/230 V a.c. (100 ... 240 V a.c.), max. 0.7 A, max. 70 W For connections designation refer to the Power Supply PS1000-A6-24.5 manual.
DC	D: 20 ... 28 V d.c. / 2.8 A (SELV/PELV or class 2) For connections designation refer to the VisuNet FLX Panel Mount manual.
Indicators/operating means	
Display	
Type	Liquid Crystal Display (LCD) with LED backlight
Screen diagonal	54.61 cm (21,5 ")
Resolution	1920 x 1080 pixels (Full HD) Aspect ratio 16:9
Color depth	24 bit (16.7 M) color
Contrast	Typically 22GT: 1000:1 22FC: 5000:1
Brightness	Configurable display options: 22GT: 250 cd/m ² 22FC: 300 cd/m ²
Reading angle	22GT: 178 ° in all directions 22FC: 170 ° horizontal, 160 ° vertical
Life span	22GT: back lamp life: 30.000 hrs typical half life, at 25 °C (77 °F) 22FC: back lamp life: 50.000 hrs typical half life, at 25 °C (77 °F)
Input devices	
Touchscreen	10-finger multi-touch, glove-friendly Configurable display options: 22GT: Capacitive touch, no optical bonding 22FC: Capacitive touch, optical bonding
Keyboard	Optional: Foil keyboard with different pointing device options available (see EXTA4 datasheet)
Interface	
Interface type	1 x DisplayPort 1.2 (DP++) 1 x mini DisplayPort 1.2 (DP++ w/ mono locking screw) 1 x Audio Line-out 2 x USB Ex i ports prepared for Pepperl+Fuchs intrinsically safe keyboard 2 x USB 3.1 Gen1 (5 Gbps) ports 1 x USB 2.0 port 2 x LAN ports (RJ45, 10/100/1000 Mbps) 2 x RS232/422/485 (BIOS configurable) with 5V/12V to power peripherals (1 x DB9 male + 1 x RJ45)
Directive conformity	
Electromagnetic compatibility	
Directive 2014/30/EU	EN 61326-1:2013 (ind. Locations) EN 61000-6-4:2007+A1:2011
Explosion protection	
Directive 2014/34/EU	EN IEC 60079-0:2018 EN IEC 60079-7:2015/A1:2018 EN 60079-11:2012 EN 60079-31:2014
RoHS	
Directive 2011/65/EU (RoHS)	EN IEC 63000:2018
Software	

Release date: 2023-11-02 Date of issue: 2023-11-02 Filename: t193552_eng.pdf

Refer to "General Notes Relating to Pepperl+Fuchs Product Information".

Pepperl+Fuchs Group
www.pepperl-fuchs.com

USA: +1 330 486 0002
pa-info@us.pepperl-fuchs.com

Germany: +49 621 776 2222
pa-info@de.pepperl-fuchs.com

Singapore: +65 6779 9091
pa-info@sg.pepperl-fuchs.com

Technical Data

Operating system	Microsoft® Windows® 10 IoT Enterprise 2019 LTSC (x64)
Ambient conditions	
Operating temperature	0 ... 40 °C (32 ... 104 °F)
Storage temperature	-20 ... 65 °C (-4 ... 149 °F)
Relative humidity	max. relative humidity 93% at 40°C (non-condensing) according to EN60068-2-78
Climatic conditions	Passive cooling, no rotating parts.
Altitude	Operating altitude max. 2000 m
Shock resistance	18 shocks 15 g, 11 ms all axis, IEC 60068-2-27
Vibration resistance	10 ... 150 Hz, +/- 0.075 mm, 1g, 10 cycles per axis according to EN60068-2-6
Mechanical specifications	
Degree of protection	IP66/Type 4X
Material	Housing: Stainless steel AISI304 (1.4301) Surface finish: Bead blasted, typical surface roughness 1,6 µm
Installation	System with enclosure
Mass	approx. 16 kg approx. 18 kg with AC Power Supply
Dimensions	577 mm x 466 mm x 233 mm
International approvals	
UL approval	
Approved for	<p>UL OrdLoc UL approval E223772 UL61010-1 Ed.3 UL 61010-2-201 Ed2 CAN/CSA C22.2 No 61010-1-12 CAN/CSA C22.2 No 61010-2-201</p> <p>UL HazLoc UL approval E492874</p> <p>Non-Incendive circuits for CL I, DIV 2, GP A-D CL II, DIV 2, GP F, G CL III Non-Incendive circuits for CL I, ZN 2, IIC CL II, ZN 22, IIIB CL III, ZN 22, IIIA Install per drawing 116-0478</p> <p>Mounting in CL I, DIV 2, GP A-D, T4 CL II, DIV 2, GP F, G CL III Mounting in CL I, ZN 2, IIC, T4 CL II, ZN 22, IIIB CL III, ZN 22, IIIA</p>
ATEX approval	
ATEX certificate	UL 22 ATEX 2481X
ATEX marking	II 3 G Ex ec [ic Gc] IIC T4 Gc II 3 D Ex tc [ic Dc] IIIC T85°C Dc
IECEX approval	
IECEX certificate	IECEX ULD 22.0019X
IECEX marking	Ex ec [ic Gc] IIC T4 Gc Ex tc [ic Dc] IIIC T85°C Dc
IECEX standard	IEC 60079-0:2017 Ed 7.0 IEC 60079-7:2017 Ed 5.1 IEC 60079-11:2011 Ed 6.0 IEC 60079-31:2013 Ed. 2

Release date: 2023-11-02 Date of issue: 2023-11-02 Filename: t193552_eng.pdf

Type Code

PC-320S-*

Model	Explosion protection	Temperature	Display unit	Power supply unit	Computing platform	RAM	Storage	Operating System & Software	Housing	Options
Model										
PC-320S-	Personal computer - "System with Enclosure"									
Explosion protection										
	N	Industrial, general purpose (UL Ord Loc Listed for US & Canada)								
	L	ATEX & IECEx Zone 2/22 and Class I, II, III Div 2								
Temperature										
	A-	0 ... 40 °C								
Display unit										
	22GT-	21.5 " (16:9), Full HD (1920 x 1080), capacitive touch, no optical bonding								
	22FC-	21.5 " (16:9), Full HD (1920 x 1080), capacitive touch, optical bonding								
Power supply unit										
	D-	24 V DC								
	A-	115/230 V AC, 50-60 Hz								
Computing platform										
	1N	Intel Celeron								
RAM										
	B	1x 8 GB, industrial temperature grade								
	C	1x 16 GB, industrial temperature grade								
Storage										
	D	256 GB, industrial temperature grade, M.2 NVMe								
	E	512 GB, industrial temperature grade, M.2 NVMe								
Operating System & Software										
	1	Windows® 10 IoT Enterprise 2019 x64 LTSC								
Housing										
	P1-	preinstalled into AG-3200-* enclosure, surface finish 0.8-µm brushed								
Options										
	NN0	Standard								

Example: PC320S-NA-22GT-D-1NAA1H1-NN0

Release date: 2023-11-02 Date of issue: 2023-11-02 Filename: t193552_eng.pdf