



Multiturn absolute encoder

AVM58-H*

- Industrial standard housing Ø58 mm
- 30 Bit multiturn
- Hardware encoder
- Data transfer up to 2 MBaud
- Optically isolated RS 422 interface
- Servo or clamping flange



Dimensions

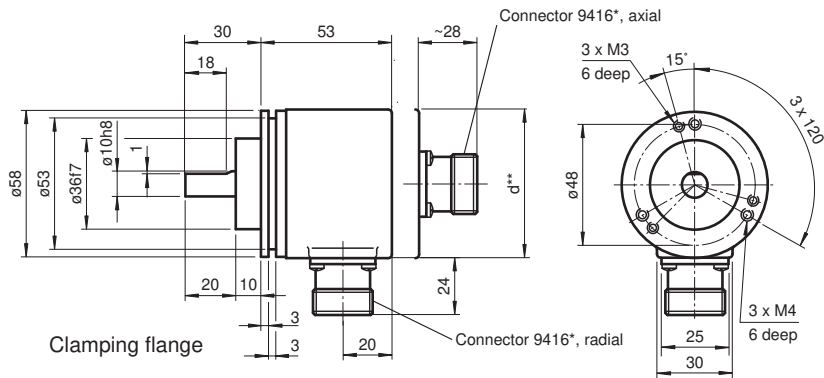

** Aluminium: d = 59, stainless steel: d = 61

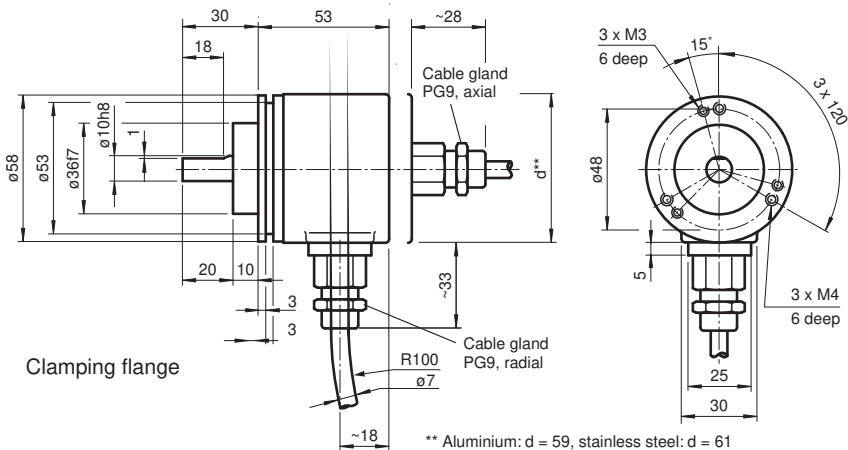

** Aluminium: d = 59, stainless steel: d = 61

Release date: 2022-04-21 Date of issue: 2022-12-12 Filename: t20460_eng.pdf

Refer to "General Notes Relating to Pepperl+Fuchs Product Information".

Pepperl+Fuchs Group
www.pepperl-fuchs.com

USA: +1 330 486 0001
fa-info@us.pepperl-fuchs.com

Germany: +49 621 776 1111
fa-info@de.pepperl-fuchs.com

Singapore: +65 6779 9091
fa-info@sg.pepperl-fuchs.com

PF PEPPERL+FUCHS

Dimensions

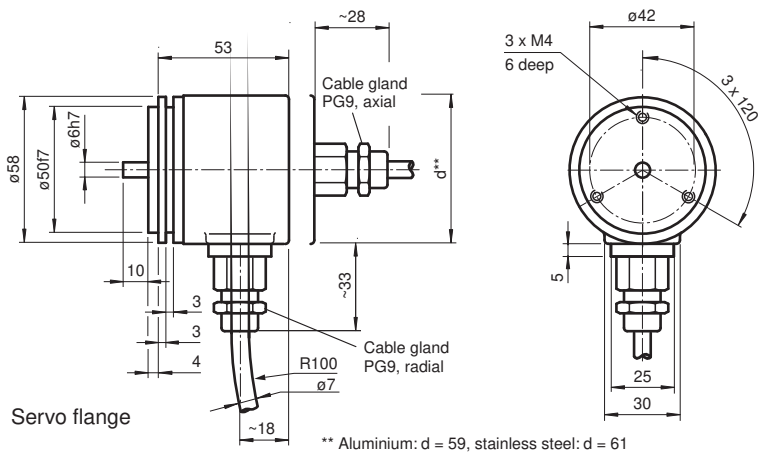
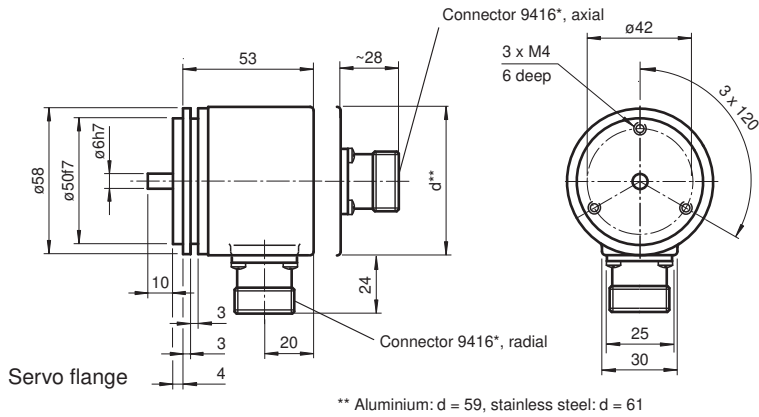

Technical Data

Functional safety related parameters

MTTF _d	150 a
Mission Time (T _M)	20 a
L _{10h}	1.9 E+11 at 6000 rpm and 20/40 N axial/radial shaft load
Diagnostic Coverage (DC)	0 %

Electrical specifications

Operating voltage	U _B	10 ... 30 V DC
No-load supply current	I ₀	max. 180 mA
Linearity		± 2 LSB at 16 Bit, ± 1 LSB at 13 Bit, ± 0,5 LSB at 12 Bit
Output code		Gray code, binary code
Code course (counting direction)		cw descending (clockwise rotation, code course descending)

Interface

Interface type	SSI
Monoflop time	20 ± 10 µs
Resolution	
Single turn	up to 16 Bit
Multiturn	14 Bit
Overall resolution	up to 30 Bit
Transfer rate	0.1 ... 2 MBit/s
Voltage drop	U _B - 2.5 V
Standard conformity	RS 422



Input 1

Release date: 2022-04-21 | Date of issue: 2022-12-12 | Filename: t20460_eng.pdf

Technical Data

Input type		Selection of counting direction (cw/ccw)
Signal voltage		
High		10 ... 30 V
Low		0 ... 2 V
Input current		< 6 mA
Signal duration		min. 10 ms
Switch-on delay		< 0.001 ms
Input 2		
Signal duration		min. 10 ms
Connection		
Connector		type 9416 (M23), 12-pin, type 9416L (M23), 12-pin
Cable		Ø7 mm, 6 x 2 x 0.14 mm ² , 1 m
Standard conformity		
Degree of protection		DIN EN 60529, IP65
Climatic testing		DIN EN 60068-2-3, no moisture condensation
Emitted interference		EN 61000-6-4:2007
Noise immunity		EN 61000-6-2:2005
Shock resistance		DIN EN 60068-2-27, 100 g, 3 ms
Vibration resistance		DIN EN 60068-2-6, 10 g, 10 ... 2000 Hz
Approvals and certificates		
UL approval		cULus Listed, General Purpose, Class 2 Power Source
Ambient conditions		
Operating temperature		-40 ... 85 °C (-40 ... 185 °F)
Storage temperature		-40 ... 85 °C (-40 ... 185 °F)
Mechanical specifications		
Material		
Combination 1		housing: powder coated aluminum flange: aluminum shaft: stainless steel
Combination 2 (Inox)		housing: stainless steel flange: stainless steel shaft: stainless steel
Mass		approx. 460 g (combination 1) approx. 800 g (combination 2)
Rotational speed		max. 12000 min ⁻¹
Moment of inertia		50 gcm ²
Starting torque		< 5 Ncm
Shaft load		
Axial		40 N
Radial		110 N

Accessories

	9203	Angled flange
	9300	Mounting bracket for servo flange
	MBT-36ALS	Spring-loaded mounting bracket with a diameter of 36 mm

Function

This multiturn absolute encoder with modern fast technology transmits a position value corresponding to the shaft setting via the SSI interface (Synchronous Serial Interface). The maximum resolution of the AVM58-H is maximum 65536 steps per revolution at 16384 revolutions.

In contrast to the AVM58 series the encoder does not have a microcontroller. Thus, it is a pure hardware encoder.

The control module sends a clock bundle to the absolute encoder to obtain the position data. The rotary encoder then sends the position data synchronous to the cycles of the control module. It is possible to select the counting direction with the function input.

This multiturn absolute encoder is available in a clamping flange design with a shaft diameter of 10 mm x 20 mm, or in a servo flange design with a shaft diameter of 6 mm x 10 mm. The electrical connection is made by a 12-pin round plug connector. It is also possible to obtain a version with a 1 m cable connector.

Connection

Signal	Cable Ø7 mm, 12-core	Connector 9416, 12-pin	Connector 9416L, 12-pin	Explanation
GND (encoder)	White	1	1	Power supply
U _b (encoder)	Brown	2	8	Power supply
Clock (+)	Green	3	3	Positive cycle line
Clock (-)	Yellow	4	11	Negative cycle line
Data (+)	Grey	5	2	Positive transmission data
Data (-)	Pink	6	10	Negative transmission data
Reserved	Blue	7	12	Not wired, reserved
V/R	Red	8	5	Input for selection of counting direction
Reserved	Black	9	9	Not wired, reserved
Reserved	Violet	10	4	Not wired, reserved
Reserved	Grey/Pink	11	6	Not wired, reserved
Reserved	Red/Blue	12	7	Not wired, reserved

Additional Information

Description

The Synchronous Serial Interface was specially developed for transferring the output data of an absolute encoder to a control device. The control module sends a clock bundle and the absolute encoder responds with the position value.

Thus only 4 lines are required for the clock and data, no matter what the resolution of the rotary encoder is. The RS 422 interface is optically isolated from the power supply.

SSI signal course Standard

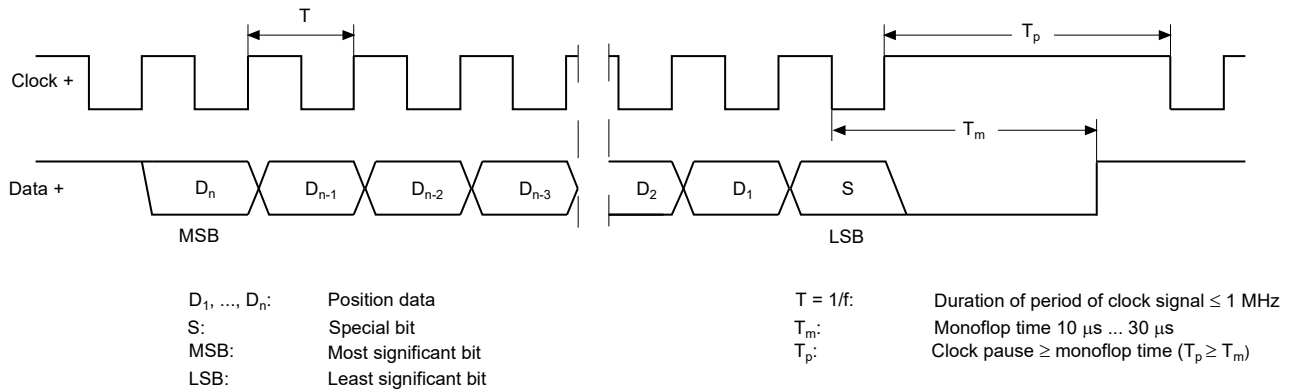

SSI output format Standard

- At idle status signal lines "Data +" and "Clock +" are at high level (5 V).
- The first time the clock signal switches from high to low, the data transfer in which the current information (position data (D_n) and special bit (S)) is stored in the encoder is introduced.
- The highest order bit (MSB) is applied to the serial data output of the encoder with the first rising pulse edge.
- The next successive lower order bit is transferred with each following rising pulse edge.
- After the lowest order bit (LSB) has been transferred the data line switches to low until the monoflop time T_m has expired.
- No subsequent data transfer can be started until the data line switches to high again or the time for the clock pause T_p has expired.
- After the clock sequence is complete, the monoflop time T_m is triggered with the last falling pulse edge.
- The monoflop time T_m determines the lowest transmission frequency.

SSI output format ring slide operation (multiple transmission)

- In ring slide operation, multiple transmission of the same data word over the SSI interface makes it possible to offer the possibility of detecting transmission errors.
- In multiple transmission, 25 bits are transferred per data word in standard format.
- If the clock change is not interrupted after the last falling pulse edge, ring slide operation automatically becomes active. This means that the information that was stored at the time of the first clock change is generated again.
- After the first transmission, the 26th pulse controls data repetition. If the 26th pulse follows after an amount of time greater than the monoflop time T_m , a new current data word will be transmitted with the following pulses.



If the pulse line is exchanged, the data word is generated offset.
Ring slide operation is possible up to max. 13 bits.

Block diagram

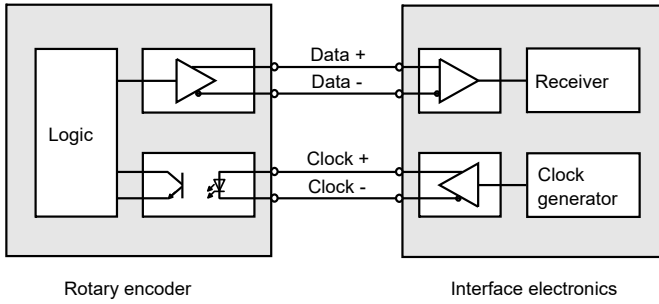

Line length

Line length in m	Baudrate in kHz
< 50	< 400
< 100	< 300
< 200	< 200
< 400	< 100

Input

The selection of the counting direction input (V/R) is activated with 0-level.

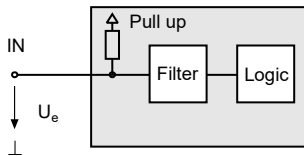

Type Code

Release date: 2022-04-21 Date of issue: 2022-12-12 Filename: t20460_eng.pdf

Order code

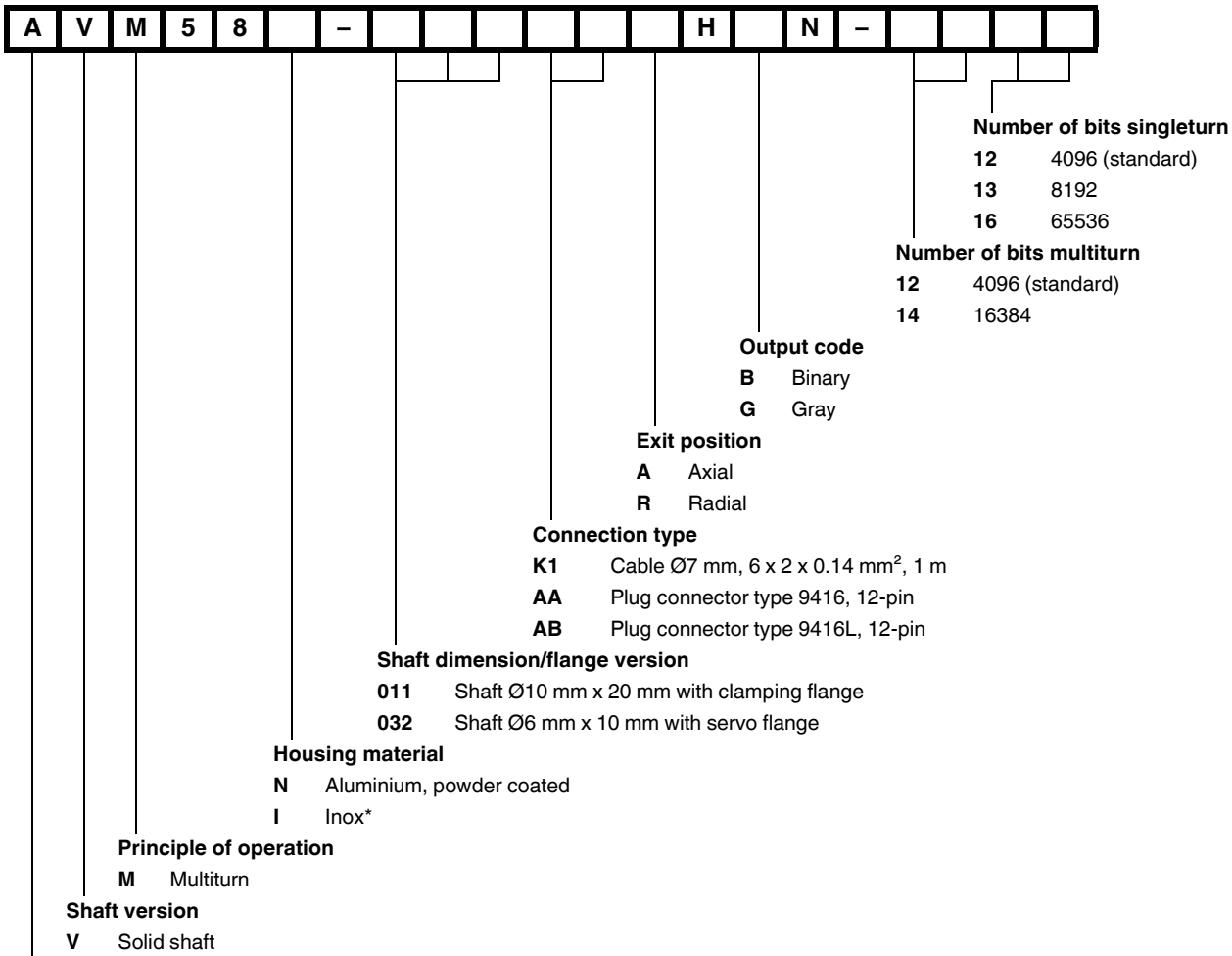

Data format

A SSI (Synchronous Serial Interface)

*Housing material I only available with axial exit position.

Installation

Anti-interference measures

The use of highly sophisticated microelectronics requires a consistently implemented anti-interference and wiring concept. This becomes all the more important the more compact the constructions are and the higher the demands are on the performance of modern machines.

The following installation instructions and proposals apply for "normal industrial environments". There is no ideal solution for all interfering environments.

When the following measures are applied, the encoder should be in perfect working order:

- Termination of the serial line with a 120 Ω resistor (between Receive/Transmit and Receive/Transmit) at the beginning and end of the serial line (e. g. the control and the last encoder).
- The wiring of the encoder should be laid at a large distance to energy lines which could cause interferences.
- Cable cross-section of the screen at least 4 mm².
- Cable cross-section at least 0,14 mm².
- The wiring of the screen and 0 V should be arranged radially, if and when possible.
- Do not kink or jam the cables.
- Adhere to the minimum bending radius as given in the data sheet and avoid tensile as well as shearing load.

Operating instructions

Every encoder manufactured by Pepperl+Fuchs leaves the factory in a perfect condition. In order to ensure this quality as well as a faultless operation, the following specifications have to be taken into consideration:

- Avoid any impact on the housing and in particular on the encoder shaft as well as the axial and radial overload of the encoder shaft.
- The accuracy and service life of the encoder is guaranteed only, if a suitable coupling is used.
- The operating voltage for the encoder and the follow-up device (e. g. control) has to be switched on and off simultaneously.

Release date: 2022-04-21 Date of issue: 2022-12-12 Filename: L20460_eng.pdf

Refer to "General Notes Relating to Pepperl+Fuchs Product Information".

- Any wiring work has to be carried out with the system in a dead condition.
- The maximum operating voltages must not be exceeded. The devices have to be operated at extra-low safety voltage.

Notes on connecting the electric screening

The immunity to interference of a plant depends on the correct screening. In this field installation faults occur frequently. Often the screen is applied to one side only, and is then soldered to the earthing terminal with a wire, which is a valid procedure in LF engineering. However, in case of EMC the rules of HF engineering apply.

One basic goal in HF engineering is to pass the HF energy to earth at an impedance as low as possible as otherwise energy would discharge into the cable. A low impedance is achieved by a large-surface connection to metal surfaces.

The following instructions have to be observed:

- Apply the screen on both sides to a "common earth" in a large surface, if there is no risk of equipotential currents.
- The screen has to be passed behind the insulation and has to be clamped on a large surface below the tension relief.
- In case of cable connections to screw-type terminals, the tension relief has to be connected to an earthed surface.
- If plugs are used, metallised plugs only should be fitted (such as sub D plugs with metallised housing). Please observe the direct connection of the tension relief to the housing.

Advantage:	metallised connector, shield
relief	clamped with the strain clamp
Disadvantage:	soldering shield on



Safety instructions

Please observe the national safety and accident prevention regulations as well as the subsequent safety instructions in these operating instructions when working on encoders.

If failures cannot be remedied, the device has to be shut down and has to be secured against accidental operation. Repairs may be carried out only by the manufacturer. Entry into and modifications of the device are not permissible.

Tighten the clamping ring only, if a shaft has been fitted in the area of the clamping ring (hollow shaft encoders). Tighten all screws and plug connectors prior to operating the encoder.

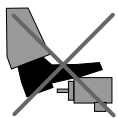

Do not stand on the encoder!

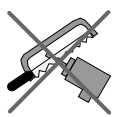

Do not remachine the drive shaft!

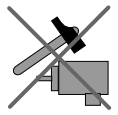

Avoid impact!



Do not remachine the housing!

Release date: 2022-04-21 Date of issue: 2022-12-12 Filename: t20460_eng.pdf

Refer to "General Notes Relating to Pepperl+Fuchs Product Information".