



Operator Workstation (PC)

VisuNet GXP PC Zone 1/21 (2024 Generation)

PC-GXP1100-19S-* -P5/P6*

- 19 in (48 cm) display
- PC solution with pre-installed Windows® operating system
- Lightweight design
- Completely modular system for easy field maintainability
- Flush or bezel mounting options
- IP66 rating for each individual component and entire system with housing
- Certified for ATEX and IECEx Zone 1/21
- UL listed for USA and Canada

VisuNet GXP PC Zone 1/21 (2024 Generation, Intel® Atom Elkhart Lake Processor)



Function

The VisuNet GXP PC (PC-GXP1100-19S*/PC-GXP1200-19S*) is a lightweight modular operator workstation for use in hazardous locations according to ATEX and IECEx Zone 1/21 as well as Class I and II, Division 2, and Class III. Certification for Class I, Zone 2; Class II, Zone 22; and Class III, Zone 22 is also available.

The system assembly consists of three core components that are fieldreplaceable by the customer.

The display unit (DPU1100-*/DPU1200-*) is a hazardous-location rated display panel with an optional 10 finger multitouch sensor. The display and touchsensor are optically bonded with the hardened front glass.

The PC unit (PCU1100-*/PCU1200-*) is a hazardous-location rated computing unit that runs a pre-installed Microsoft Windows operating system. The PC unit allows users to install individual software packages such as SCADA applications to visualize and control their automation application.

The power supply units (PSU1100-*/PSU1200-*) are hazardous-location rated power supplies that provide the PCU and DPU devices with 24 V DC power.

As a standard mounting option, a bezel is available that allows the panel to be mounted into the system housing or into a cabinet (requires mounting kit). The panel can also be flush-mounted into a cabinet from the back with additional mounting brackets.

Dimensions

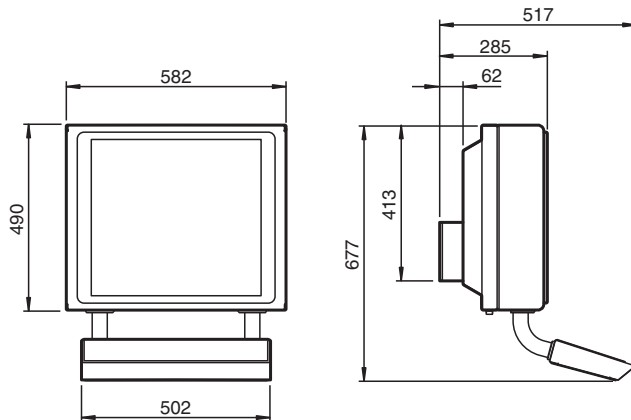

Release date: 2024-04-30 Date of issue: 2024-04-30 Filename: t217611_eng.pdf

Refer to "General Notes Relating to Pepperl+Fuchs Product Information".

Pepperl+Fuchs Group
www.pepperl-fuchs.com

USA: +1 330 486 0002
pa-info@us.pepperl-fuchs.com

Germany: +49 621 776 2222
pa-info@de.pepperl-fuchs.com

Singapore: +65 6779 9091
pa-info@sg.pepperl-fuchs.com

PF PEPPERL+FUCHS

Dimensions

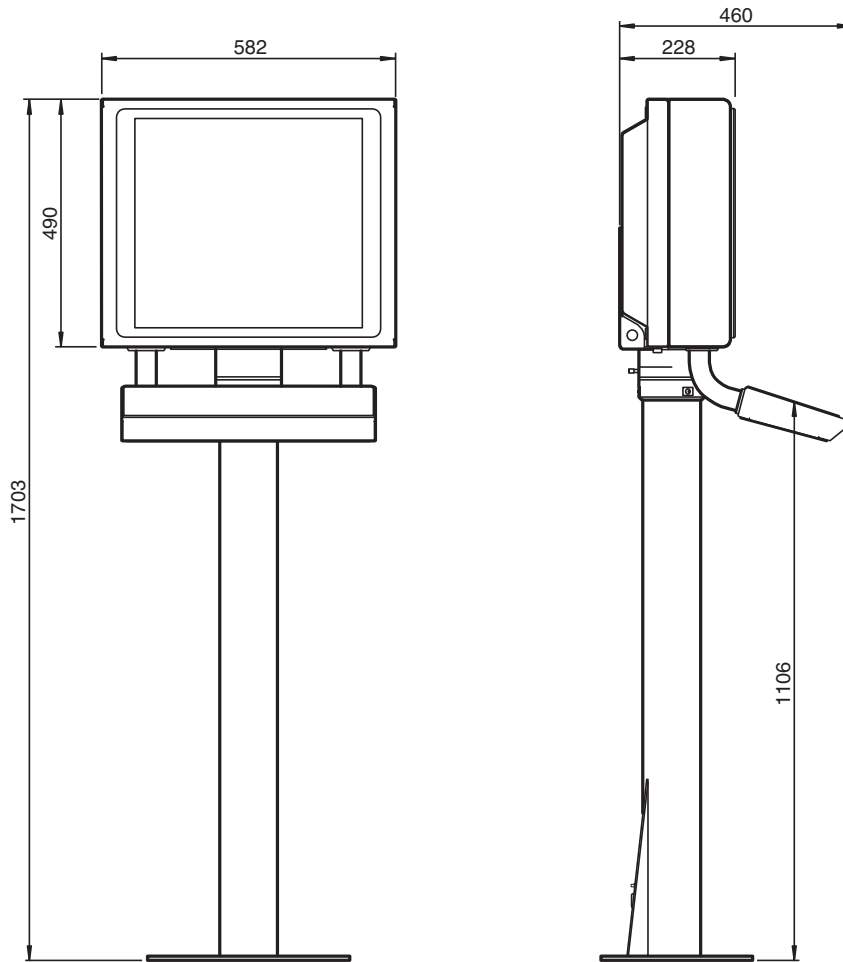

Technical Data

General specifications	
Type	Personal Computer
Hardware	
Processor	Intel® Atom Elkhart Lake x6425RE
RAM	8 GB
Mass storage	240 GByte industrial grade SSD optional: 480 GByte SSD
Supply	
Power consumption	
AC	115/230 V AC, 0.4 ... 0.7 A, 50/60 Hz
DC	18 ... 36 V DC, 1.5 ... 3 A
Indicators/operating means	
Display	
Type	Liquid Crystal Display (LCD) with LED backlight
Screen diagonal	48.26 cm (19 inch)
Resolution	1280 x 1024 (SXGA), Aspect ratio 5:4
Color depth	24 bit (16.7 M) color
Contrast	1000:1
Brightness	450 cd/m ² (nit)
Reading angle	170° horizontal 160° vertical
Life span	back lamp life: 50.000 hrs typical half life, at 25 °C (77 °F)
Input devices	

Release date: 2024-04-30 Date of issue: 2024-04-30 Filename: t217611_eng.pdf

Refer to "General Notes Relating to Pepperl+Fuchs Product Information".

Pepperl+Fuchs Group
www.pepperl-fuchs.com

USA: +1 330 486 0002
pa-info@us.pepperl-fuchs.com

Germany: +49 621 776 2222
pa-info@de.pepperl-fuchs.com

Singapore: +65 6779 9091
pa-info@sg.pepperl-fuchs.com

 PEPPERL+FUCHS

Technical Data

Touch screen	optional: projective capacitive; 10 finger multi-touch, glove friendly
Keyboard	Foil keyboard with different pointing device options available (see EXTA4 datasheet)
Interface	
Interface type	<p>Standard:</p> <ul style="list-style-type: none"> 1 x Ethernet 100/1000BASE-TX (Ex e) or 1 x fiber optic 1000BASE-SX (Multimode) or 1 x fiber optic 1000BASE-LX (Singlemode), 1 x USB 2.0 (Ex e), 2 x USB 1.1 (Ex i; intended for Pepperl+Fuchs keyboard and mouse), 1 x DC or AC power in (via power supply unit) <p>Optional:</p> <p>"interface 3": 1 x barcode reader interface for wired 1-D scanners IDM-160-D*, IDM-Z1-160-D-* and IDM-164-D-* and base station IDMx61-B*, IDM-Z1-x61-B* and IDM-Z1-x64-B* (Ex i)</p> <p>"interface 4": 1 x barcode reader interface for wired 2-D scanner IDM-Z1-260-D* and IDM-Z1-264-D* (Ex i)</p> <p>"interface 5": 1 x RS-232 interface with Power Supply for miscellaneous devices and peripherals (Ex i)</p> <ul style="list-style-type: none"> 1 x RS-232 (Ex e) 1 x RS-485 (Ex e) 1 x Ethernet 100/1000Base-TX (Ex e) <p>Bluetooth v4.0, communication distance up to 30 m in open terrain, transmission power +8 dBm, transmission frequency 2.402 ... 2.48 GHz</p>
Directive conformity	
Electromagnetic compatibility	
Directive 2014/30/EU	EN 61326-1:2013 (industrial locations) non-Bluetooth products only
Radio and telecommunication terminal equipment	
Directive 2014/53/EU	EN 301 328 V2.1.1 EN 301 489-1 V2.1.1 EN 301 489-17 V3.1.1 Bluetooth products only
RoHS	
Directive 2011/65/EU (RoHS)	EN 50581:2012-09
Software	
Operating system	Microsoft® Windows® 10 IoT Enterprise 2021 LTSC (x64)
Ambient conditions	
Operating temperature	-20 ... 50 °C (-4 ... 122 °F)
Storage temperature	-20 ... 60 °C (-4 ... 140 °F)
Relative humidity	93% at 40°C, non-condensating, according to EN60068-2-78
Altitude	Operating altitude max. 2000 m
Shock resistance	18 shocks 15 g , 11 ms all axis, IEC 60068-2-27
Vibration resistance	10 ... 150 Hz, +/- 0.075 mm , 1g, 10 cycles per axis according to EN60068-2-6
Mechanical specifications	
Degree of protection	IP66 (individual components and entire system with housing)
Material	<p>Internal:</p> <p>Panel: anodized aluminum (TCU, PSU), powder coated aluminum (DPU)</p> <p>External:</p> <p>Bezel: stainless steel AISI 304 (1.4301)</p> <p>System housing: stainless steel AISI 304 (1.4301), bead blasted, typical surface roughness Ra = 1.6 µm</p>
Installation	<p>Flush-mount installation (requires customized mounting kit)</p> <p>Panel-mount installation into system housing with bezel</p> <p>Panel-mount installation into cabinet with Bezel and standard mounting kit</p>
Mass	panel with DC: 22 kg , panel with AC: 23 kg , system housing AG1: 19 kg
Dimensions	<p>panel with DC: 524 mm x 453 mm x 120 mm</p> <p>panel with AC: 524 mm x 453 mm x 137 mm</p> <p>panel with AG1 housing: 582 mm x 490 mm x 224 mm</p>
Data for application in connection with hazardous areas	
EU-type examination certificate	BVS 17 ATEX E 036 X
Marking	<p>Ⓜ II 2G Ex eb q ib [ib] IIC T4 IP66 Gb</p> <p>Ⓜ II 2D Ex tb [ib] IIC T85°C IP66 Db</p>

Release date: 2024-04-30 Date of issue: 2024-04-30 Filename: t217611_eng.pdf

Refer to "General Notes Relating to Pepperl+Fuchs Product Information".

 Pepperl+Fuchs Group
www.pepperl-fuchs.com

 USA: +1 330 486 0002
pa-info@us.pepperl-fuchs.com

 Germany: +49 621 776 2222
pa-info@de.pepperl-fuchs.com

 Singapore: +65 6779 9091
pa-info@sg.pepperl-fuchs.com

 **PEPPERL+FUCHS**

Technical Data

Directive conformity		
Directive 2014/34/EU		EN 60079-0:2012+A11:2013, EN 60079-5:2015, EN 60079-7:2015, EN 60079-11:2012, EN 60079-31:2014
International approvals		
UL approval		E492874
Approved for		Class I, Division 2, Groups A, B, C, D T4; Zone 2, Group IIC T4 Class II, Division 2, Groups F, G T4; Zone 22, Group IIIB T85 Class III; Zone 22, Group IIIA T85
IECEX approval		IECEX BVS 17.0029X
Approved for		Ex eb q ib [ib] IIC T4 IP66 Gb Ex tb [ib] IIC T85°C IP66 Db
Standards		IEC 60079-0:2011, IEC 60079-5:2015, IEC 60079-7:2015, IEC 60079-11:2011, IEC 60079-31:2013

Type Code

PC-GXP 19 inches

PC-GXP	(1)	(2)	(3)	(4)-	(5)-	(6)	(7)	(8)	(9)-	(10)-	(11)
--------	-----	-----	-----	------	------	-----	-----	-----	------	-------	------

Model	
PC-GXP	VisuNet GXP Personal Computer System

(1)	Zone
1100-	Zone 1/21
1200-	Zone 2/22

(2)	Display Unit
19S	19 inches, SXGA (1280 x 1024)

(3)	Front Glass & Touch
N	Anti-glare security glass, no touch
C	Anti-glare security glass, projective capacitive 10-finger multitouch

(4)-	Interfaces
1-	5 x capacitive system front keys
2-	5 x capacitive system front keys and Bluetooth® interface

(5)-	Power Supply Unit
D-	18 ... 36 V DC
A-	115/230 V AC, 50/60 Hz

(6)	Interfaces
E	1 x 1000BASE-T LAN Ex e, 1x USB Ex e, 2x USB Ex i
S	1 x 1000BASE-SX fiber optic (Multimode), 1x USB Ex e, 2x USB Ex i
L	1 x 1000BASE-LX fiber optic (Single mode), 1x USB Ex e, 2x USB Ex i

(7)	Module A
N	No additional interface module
1	1 x RS-232 Ex e
2	1 x RS-485 Ex e
3	1 x Ex i interface for wired 1-D barcode readers IDM-160-D*, IDM-Z1-160-D*, IDM-Z1-164-D* and base station IDMx61-B*, IDM-Z1-x61-B-* and IDM-Z1-x64-B-*
4	1 x Ex i interface for 2-D barcode readers IDM-Z1-260-D* and IDM-Z1-264-D*
5	1 x RS-232 Ex i interface for miscellaneous devices and peripherals
E	1 x 1000BASE-T LAN Ex e

(8)	Module B
N	No additional interface module
1	1 x RS-232 Ex e
2	1 x RS-485 Ex e
3	1 x Ex i interface for wired 1-D barcode readers IDM-160-D*, IDM-Z1-160-D*, IDM-Z1-164-D* and base station IDMx61-B*, IDM-Z1-x61-B-* and IDM-Z1-x64-B-*
4	1 x Ex i interface for 2-D barcode readers IDM-Z1-260-D* and IDM-Z1-264-D*
5	1 x RS-232 Ex i interface for miscellaneous devices and peripherals
E	1 x 1000BASE-T LAN Ex e

Release date: 2024-04-30 Date of issue: 2024-04-30 Filename: t217611_eng.pdf

Refer to "General Notes Relating to Pepperl+Fuchs Product Information".

 Pepperl+Fuchs Group
www.pepperl-fuchs.com

 USA: +1 330 486 0002
pa-info@us.pepperl-fuchs.com

 Germany: +49 621 776 2222
pa-info@de.pepperl-fuchs.com

 Singapore: +65 6779 9091
pa-info@sg.pepperl-fuchs.com

 **PEPPERL+FUCHS**

Type Code

(9)	Computing Platform
P5-	Intel® Elkhart Lake x6425RE, 8-GB RAM, 240-GB SSD, Windows® IoT Enterprise LTSC 2021
P6-	Intel® Elkhart Lake x6425RE, 8-GB RAM, 480-GB SSD, Windows® IoT Enterprise LTSC 2021

(10)-	Housing
NN-	No bezel, prepared for flush mount
S2-	Bezel; prepared for panel mounting or into AG1 housing
H2-	Installed into EX1 AG1 housing (SS304), front opening, for pedestal/ceiling/wall-arm

(11)	Options
N0	Standard, no options

Example:

RM-GXP	1100-	19S	N	1-	D-	E	N	N	P5-	S1-	N0
--------	-------	-----	---	----	----	---	---	---	-----	-----	----

Release date: 2024-04-30 Date of issue: 2024-04-30 Filename: t217611_eng.pdf