



# Operator Workstation (RM)

## VisuNet GXP Remote Monitor (RM)

### Zone 2/22 (2024 Generation)

#### RM-GXP1200-19S-\* -T4\*

- 19 in (48 cm) display
- Thin Client solution (with VisuNet RM Shell firmware)
- Lightweight design
- Completely modular system for easy field maintainability
- Flush or bezel mounting options
- IP66 rating for each individual component and entire system with housing
- Certified for ATEX and IECEx Zone 2/22
- UL listed for USA and Canada

VisuNet GXP Remote Monitor Zone 2/22 (2024 Generation, Intel® Atom Elkhart Lake Processor)



### Function

The VisuNet GXP Remote Monitor (RMGXP1100-19S\*/RM-GXP1200-19S\*) is a lightweight modular operator workstation for use in hazardous locations according to ATEX and IECEx Zone 1/21 as well as Class I and II, Division 2, and Class III. Certification for Class I, Zone 2; Class II, Zone 22; and Class III, Zone 22 is also available.

The system assembly consists of three core components that are fieldreplaceable by the customer.

The display unit (DPU1100\*/DPU1200-\*) is a hazardous-location rated display panel with an optional 10 finger multitouch sensor. The display and touchsensor are optically bonded with the hardened front glass.

The thin client unit (TCU1100\*/TCU1200-\*) is a hazardous-location rated computing unit that runs the latest Pepperl+Fuchs RM Shell firmware. The TCU allows connection to various host systems in the safe area, using standard Ethernet technology.

The power supply units (PSU1100\*/PSU1200-\*) are hazardous-location rated power supplies, providing the TCU and DPU devices with 24 V DC power.

As a standard mounting option, a bezel is available that allows the panel to be mounted into the system housing or into a cabinet (requires mounting kit). The panel can also be flush-mounted into a cabinet from the back with additional mounting brackets.

### Dimensions

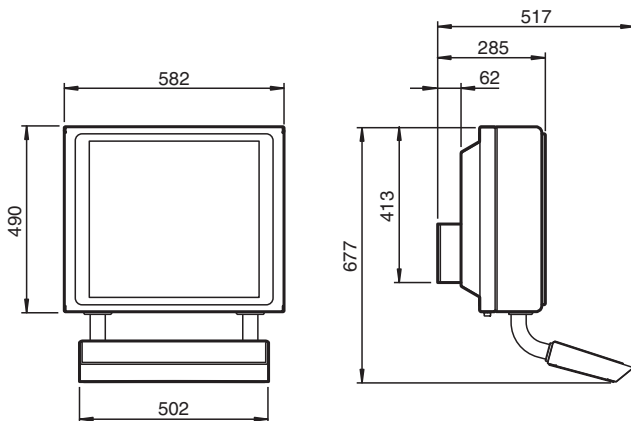

Release date: 2024-03-18 Date of issue: 2024-03-18 Filename: t217613\_eng.pdf

Refer to "General Notes Relating to Pepperl+Fuchs Product Information".

Pepperl+Fuchs Group  
www.pepperl-fuchs.com

USA: +1 330 486 0002  
pa-info@us.pepperl-fuchs.com

Germany: +49 621 776 2222  
pa-info@de.pepperl-fuchs.com

Singapore: +65 6779 9091  
pa-info@sg.pepperl-fuchs.com

**PF** PEPPERL+FUCHS

## Dimensions

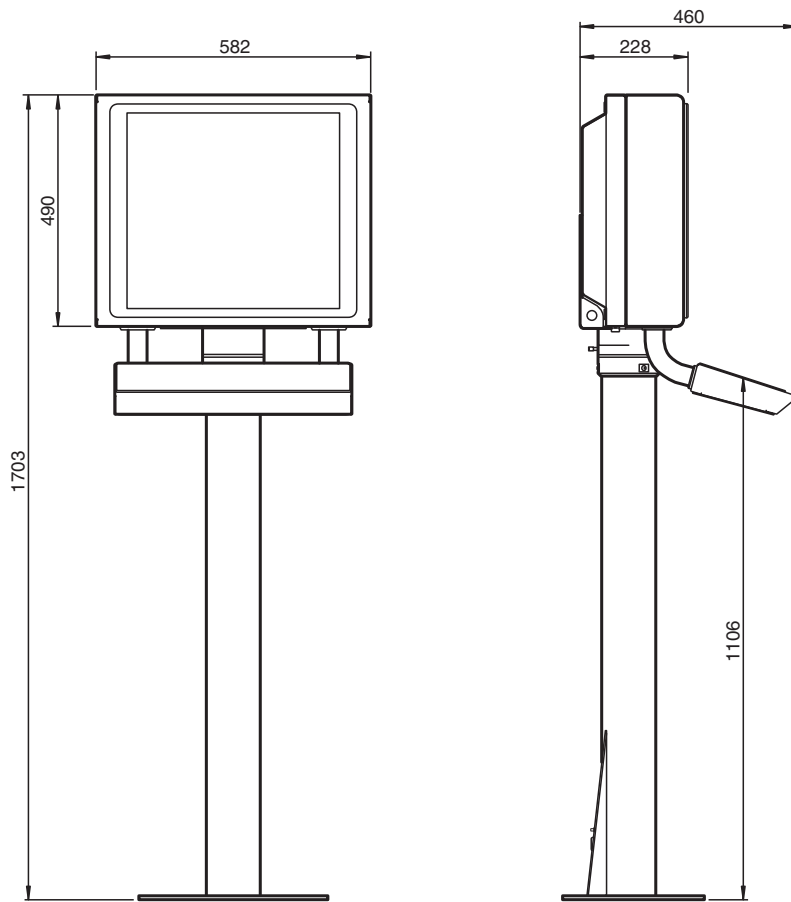

## Technical Data

General specifications	
Type	Remote Monitor
Hardware	
Processor	Intel® Atom Elkhart Lake x6211E
RAM	4 GB
Mass storage	64 GByte eMMC
Supply	
Power consumption	
AC	115/230 V AC, 0.4 ... 0.7 A, 50/60 Hz
DC	18 ... 36 V DC, 1.5 ... 3 A
Indicators/operating means	
Display	
Type	Liquid Crystal Display (LCD) with LED backlight
Screen diagonal	48.26 cm (19 inch)
Resolution	1280 x 1024 (SXGA), Aspect ratio 5:4
Color depth	24 bit (16.7 M) color
Contrast	1000:1
Brightness	450 cd/m <sup>2</sup> (nit)
Reading angle	170° horizontal 160° vertical
Life span	back lamp life: 50.000 hrs typical half life, at 25 °C (77 °F)
Input devices	

Release date: 2024-03-18 Date of issue: 2024-03-18 Filename: t217613\_eng.pdf

Refer to "General Notes Relating to Pepperl+Fuchs Product Information".

Pepperl+Fuchs Group  
www.pepperl-fuchs.com

USA: +1 330 486 0002  
pa-info@us.pepperl-fuchs.com

Germany: +49 621 776 2222  
pa-info@de.pepperl-fuchs.com

Singapore: +65 6779 9091  
pa-info@sg.pepperl-fuchs.com

 PEPPERL+FUCHS

## Technical Data

Touch screen	optional: projective capacitive; 10 finger multi-touch, glove friendly
Keyboard	Foil keyboard with different pointing device options available (see EXTA4 datasheet)
<b>Interface</b>	
Interface type	<p>Standard:</p> <ul style="list-style-type: none"> <li>1 x Ethernet 100/1000BASE-TX (Ex e) or</li> <li>1 x fiber optic 1000BASE-SX (Multimode) or</li> <li>1 x fiber optic 1000BASE-LX (Singlemode),</li> <li>1 x USB 2.0 (Ex e),</li> <li>2 x USB 1.1 (Ex i; intended for Pepperl+Fuchs keyboard and mouse),</li> <li>1 x DC or AC power in (via power supply unit)</li> </ul> <p>Optional:</p> <p>"interface 3": 1 x barcode reader interface for wired 1-D scanners IDM-160-D*, IDM-Z1-160-D-* and IDM-164-D-* and base station IDMx61-B*, IDM-Z1-x61-B* and IDM-Z1-x64-B* (Ex i)</p> <p>"interface 4": 1 x barcode reader interface for wired 2-D scanner IDM-Z1-260-D* and IDM-Z1-264-D* (Ex i)</p> <p>"interface 5": 1 x RS-232 interface with Power Supply for miscellaneous devices and peripherals (Ex i)</p> <ul style="list-style-type: none"> <li>1 x RS-232 (Ex e)</li> <li>1 x RS-485 (Ex e)</li> <li>1 x Ethernet 100/1000Base-TX (Ex e)</li> </ul> <p>Bluetooth v4.0, communication distance up to 30 m in open terrain, transmission power +8 dBm, transmission frequency 2.402 ... 2.48 GHz</p>
<b>Directive conformity</b>	
Electromagnetic compatibility	
Directive 2014/30/EU	EN 61326-1:2013 (industrial locations) non-Bluetooth products only
Radio and telecommunication terminal equipment	
Directive 2014/53/EU	EN 301 328 V2.1.1 EN 301 489-1 V2.1.1 EN 301 489-17 V3.1.1 Bluetooth products only
RoHS	
Directive 2011/65/EU (RoHS)	EN 50581:2012-09
<b>Software</b>	
Operating system	VisuNet RM Shell 6.x (based on Microsoft Windows 10 IoT Enterprise 2021 LTSC)
<b>Ambient conditions</b>	
Operating temperature	-20 ... 50 °C (-4 ... 122 °F)
Storage temperature	-20 ... 60 °C (-4 ... 140 °F)
Relative humidity	93% at 40°C, non-condensating, according to EN60068-2-78
Altitude	Operating altitude max. 2000 m
Shock resistance	18 shocks 15 g , 11 ms all axis, IEC 60068-2-27
Vibration resistance	10 ... 150 Hz, +/- 0.075 mm , 1g, 10 cycles per axis according to EN60068-2-6
<b>Mechanical specifications</b>	
Degree of protection	IP66 (individual components and entire system with housing)
Material	<p>Internal:</p> <p>Panel: anodized aluminum (TCU, PSU), powder coated aluminum (DPU)</p> <p>External:</p> <p>Bezel: stainless steel AISI 304 (1.4301)</p> <p>System housing: stainless steel AISI 304 (1.4301), bead blasted, typical surface roughness Ra = 1.6 µm</p>
Installation	<p>Flush-mount installation (requires customized mounting kit)</p> <p>Panel-mount installation into system housing with bezel</p> <p>Panel-mount installation into cabinet with Bezel and standard mounting kit</p>
Mass	panel with DC: 22 kg , panel with AC: 23 kg , system housing AG1: 19 kg
Dimensions	<p>panel with DC: 524 mm x 453 mm x 120 mm</p> <p>panel with AC: 524 mm x 453 mm x 137 mm</p> <p>panel with AG1 housing: 582 mm x 490 mm x 224 mm</p>
Note	* see nameplate: 2021 alternative, processor cannot be selected
<b>Data for application in connection with hazardous areas</b>	
EU-type examination certificate	BVS 17 ATEX E 037 X

Release date: 2024-03-18 Date of issue: 2024-03-18 Filename: t217613\_eng.pdf

## Technical Data

Marking	Ⓜ II 3G Ex ec [ib] q IIC T4 IP66 Gc Ⓜ II 3D Ex tc [ib] IIIC T85 °C IP66 Dc
Directive conformity	
Directive 2014/34/EU	EN 60079-0:2012+A11:2013, EN 60079-7:2015, EN 60079-11:2012, EN 60079-31:2014
<b>International approvals</b>	
UL approval	E492874
Approved for	Class I, Division 2, Groups A, B, C, D T4; Zone 2, Group IIC T4 Class II, Division 2, Groups F, G T4; Zone 22, Group IIIB T85 Class III; Zone 22, Group IIIA T85
IECEx approval	IECEx BVS 17.0029X
Approved for	Ex ec [ib] q IIC T4 IP66 Gc Ex tc [ib] IIIC T85 °C IP66 Dc
Standards	IEC 60079-0:2011, IEC 60079-7:2015, IEC 60079-11:2011, IEC 60079-31:2013

## Type Code

### RM-GXP 19 inches

RM-GXP	(1)	(2)	(3)	(4)-	(5)-	(6)	(7)	(8)	(9)-	(10)-	(11)
--------	-----	-----	-----	------	------	-----	-----	-----	------	-------	------

Model	
RM-GXP	VisuNet GXP Remote Monitor System

(1)	Zone
1100-	Zone 1/21
1200-	Zone 2/22

(2)	Display Unit
19S	19 inches, SXGA (1280x1024)

(3)	Front Glass & Touch
N	Anti-glare security glass, no touch
C	Anti-glare security glass, projective capacitive 10-finger multitouch

(4)-	Interfaces
1-	5 x capacitive system front keys
2-	5 x capacitive system front keys and Bluetooth® interface

(5)-	Power Supply Unit
D-	18 ... 36 V DC
A-	115/230 V AC, 50/60 Hz

(6)	Interfaces
E	1 x 1000BASE-T LAN Ex e, 1x USB Ex e, 2x USB Ex i
S	1 x 1000BASE-SX fiber optic (Multimode), 1x USB Ex e, 2x USB Ex i
L	1 x 1000BASE-LX fiber optic (Single mode), 1x USB Ex e, 2x USB Ex i

(7)	Module A
N	No additional interface module
1	1 x RS-232 Ex e
2	1 x RS-485 Ex e
3	1 x Ex i interface for wired 1-D barcode readers IDM-160-D*, IDM-Z1-160-D*, IDM-Z1-164-D* and base station IDMx61-B*, IDM-Z1-x61-B* and IDM-Z1-x64-B*
4	1 x Ex i interface for 2-D barcode readers IDM-Z1-260-D* and IDM-Z1-264-D*
5	1 x RS-232 Ex i interface for miscellaneous devices and peripherals
E	1 x 1000BASE-T LAN Ex e

(8)	Module B
N	No additional interface module
1	1 x RS-232 Ex e
2	1 x RS-485 Ex e
3	1 x Ex i interface for wired 1-D barcode readers IDM-160-D*, IDM-Z1-160-D*, IDM-Z1-164-D* and base station IDMx61-B*, IDM-Z1-x61-B* and IDM-Z1-x64-B*
4	1 x Ex i interface for 2-D barcode readers IDM-Z1-260-D* and IDM-Z1-264-D*
5	1 x RS-232 Ex i interface for miscellaneous devices and peripherals
E	1 x 1000BASE-T LAN Ex e

Release date: 2024-03-18 Date of issue: 2024-03-18 Filename: t217613\_eng.pdf

Refer to "General Notes Relating to Pepperl+Fuchs Product Information".

## Type Code

(9)	Computing Platform
T4-	Intel® Atom Elkhart Lake x6211E, 4-GB RAM, 64-GB SSD, VisuNet RM Shell 6.x (based on Windows® IoT LTSC 2021)

(10)-	Housing
NN-	No bezel, prepared for flush mounting
S2-	Bezel; prepared for panel mounting or into AG1 housing
H2-	Installed into EX1 AG1 housing (SS304), front opening, for pedestal/ceiling/wall-arm

(11)	Options
N0	Standard, no options

### Example:

RM-GXP	1100-	19S	N	1-	D-	E	N	N	T4-	S2-	N0
--------	-------	-----	---	----	----	---	---	---	-----	-----	----