

Singleturn absolute encoder

ESS58-TZ



- Industrial standard housing Ø58 mm
- Ethernet interface with TCP/IP
- 16 Bit singleturn
- Integrated webserver
- Recessed hollow shaft



Function

In addition to the CANopen-, DeviceNet-, PROFIBUS- and AS-Interface encoders, we have broadened our product line of bus-capable absolute encoders with the ESS58 for Ethernet.

Absolute rotary encoders deliver an absolute step value for each angle setting.

The absolute encoder has a maximum basic resolution of 65536 steps per revolution (16 Bits).

The Ethernet interface of this absolute encoder supports the TCP/IP protocol. The integrated webserver provides Java applets, which allow the whole parameterisation of the encoder via any web browser. In addition to various functions like resolution adjustment, e-mail-services, change of the IP address and many others, the following operation modes can be selected:

- Polled mode
- Cyclic mode
- Change of state mode

The absolute encoder is mounted directly onto the application shaft, without any coupling. Rotation of the absolute encoder is prevented by a torque rest.

Dimensions

Recessed hollow shaft

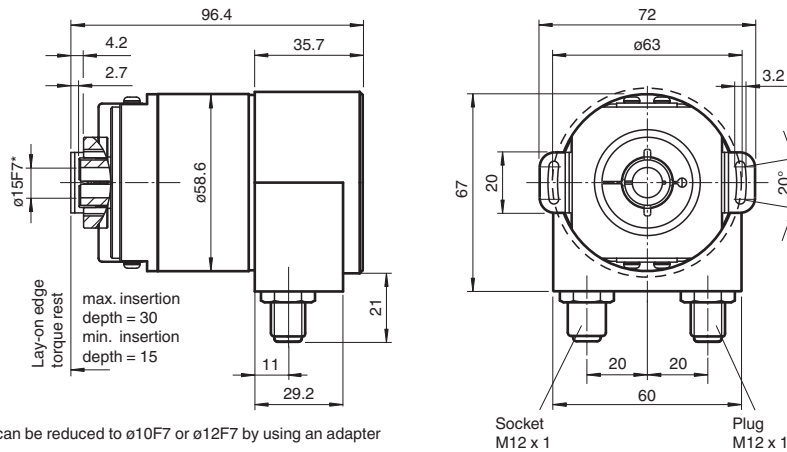

Technical Data

General specifications

Detection type	photoelectric sampling
Device type	Singleturn absolute encoder

Functional safety related parameters

MTTF _d	130 a
Mission Time (T _M)	20 a
L ₁₀	1.9 E+11 at 6000 rpm and 20/40 N axial/radial shaft load

Release date: 2022-12-12 Date of issue: 2022-12-12 Filename: t31168_eng.pdf

Refer to "General Notes Relating to Pepperl+Fuchs Product Information".

Pepperl+Fuchs Group
www.pepperl-fuchs.com

USA: +1 330 486 0001
fa-info@us.pepperl-fuchs.com

Germany: +49 621 776 1111
fa-info@de.pepperl-fuchs.com



Singapore: +65 6779 9091
fa-info@sg.pepperl-fuchs.com

PF PEPPERL+FUCHS

Technical Data

Diagnostic Coverage (DC)	0 %	
Electrical specifications		
Operating voltage	U_B	10 ... 30 V DC
Power consumption	P_0	max. 4 W
Linearity	± 0.5 LSB (12 Bit) ,	
Output code	binary code	
Code course (counting direction)	programmable, cw ascending (clockwise rotation, code course ascending) cw descending (clockwise rotation, code course descending)	
Interface		
Interface type	TCP/IP	
Resolution		
Single turn	up to 16 Bit	
Overall resolution	up to 16 Bit	
Physical	Ethernet	
Transfer rate	10 MBit/s / 100 MBit/s	
Connection		
Connector	Ethernet: 1 socket M12 x 1, 4-pin, D-coded Supply: 1 plug M12 x 1, 5-pin, A-coded	
Standard conformity		
Degree of protection	DIN EN 60529, shaft side: IP64 (without shaft seal)/IP66 (with shaft seal) housing side: IP65	
Climatic testing	DIN EN 60068-2-3, no moisture condensation	
Emitted interference	EN 61000-6-4:2007	
Noise immunity	EN 61000-6-2:2005	
Shock resistance	DIN EN 60068-2-27, 100 g, 6 ms	
Vibration resistance	DIN EN 60068-2-6, 10 g, 10 ... 1000 Hz	
Approvals and certificates		
UL approval	cULus Listed, General Purpose, Class 2 Power Source	
Ambient conditions		
Operating temperature	0 ... 60 °C (32 ... 140 °F) Standard , with Option T -40 ... 85 °C (-40 ... 185 °F)	
Storage temperature	-40 ... 85 °C (-40 ... 185 °F)	
Mechanical specifications		
Material	housing: powder coated aluminum flange: aluminum shaft: stainless steel	
Mass	approx. 500 g	
Rotational speed	max. 12000 min ⁻¹ without shaft seal max. 3000 min ⁻¹ with shaft seal	
Moment of inertia	30 gcm ²	
Starting torque	≤ 3 Ncm without shaft seal ≤ 5 Ncm with shaft seal	
Tightening torque, fastening screws	max. 1.8 Nm	
Shaft load		
Angle offset	$\pm 0.9^\circ$	
Axial offset	static: ± 0.3 mm, dynamic: ± 0.1 mm	
Radial offset	static: ± 0.5 mm, dynamic: ± 0.2 mm	

Accessories

	V15-G-YE2M-PVC	Female cordset, M12, 5-pin, PVC cable
	V15-G-YE5M-PVC	Female cordset, M12, 5-pin, PVC cable

Release date: 2022-12-12 Date of issue: 2022-12-12 Filename: t31168_eng.pdf

Refer to "General Notes Relating to Pepperl+Fuchs Product Information".

 Pepperl+Fuchs Group
www.pepperl-fuchs.com







 USA: +1 330 486 0001
fa-info@us.pepperl-fuchs.com

 Germany: +49 621 776 1111
fa-info@de.pepperl-fuchs.com

 Singapore: +65 6779 9091
fa-info@sg.pepperl-fuchs.com

 **PEPPERL+FUCHS**

Accessories

	V1SD-G-ABG-PG9	Male connector M12 straight D-coded 4-pin, for cable diameter 5 - 8 mm, shielded, field-attachable
	V1SD-G-2M-PUR-ABG-V45-G	Connection cable, M12 to RJ-45, PUR cable 4-pin, CAT5e
	V15-G-PG9	Female connector M12 straight A-coded 5-pin, for cable diameter 6 - 8 mm, field-attachable
	ACC-PACK-ABS-_S_58 ø15	Accessories set for Ø58 absolut rotary encoder with recessed hollow shaft 15 mm
	ACC-PACK-ABS-_S_58 ø14	Accessories set for Ø58 absolut rotary encoder with recessed hollow shaft 14 mm
	ACC-PACK-ABS-_S_58 ø12	Accessories set for Ø58 absolut rotary encoder with recessed hollow shaft 12 mm
	ACC-PACK-ABS-_S_58 ø10	Accessories set for Ø58 absolut rotary encoder with recessed hollow shaft 10 mm

Release date: 2022-12-12 Date of issue: 2022-12-12 Filename: t31168_eng.pdf

Refer to "General Notes Relating to Pepperl+Fuchs Product Information".

Pepperl+Fuchs Group
www.pepperl-fuchs.com

USA: +1 330 486 0001
fa-info@us.pepperl-fuchs.com

Germany: +49 621 776 1111
fa-info@de.pepperl-fuchs.com

Singapore: +65 6779 9091
fa-info@sg.pepperl-fuchs.com

Connection

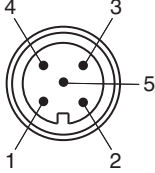
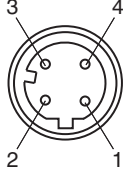
Pin	Male connector M12 x 1, 5-pin, A-coded	Female connector M12 x 1, 4-pin, D-coded
1	+ 24 V	Tx +
2	+ 24 V	Rx +
3	0 V	Tx -
4	0 V	Rx -
5	PE	
		

Indication

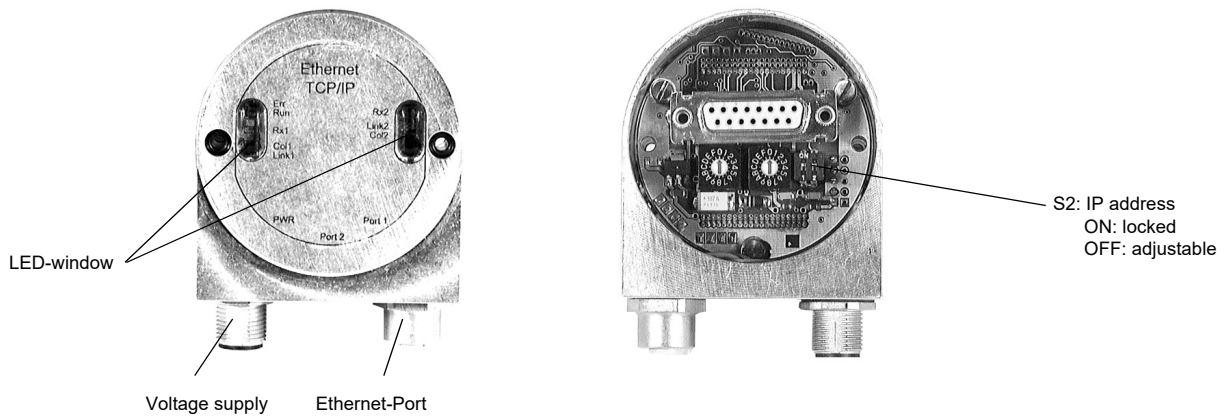

LED-indicators

LED	Colour	Meaning
Rx1	yellow	Data traffic on Port 1
Link1	green	Connection to an Ethernet device on Port 1
Col1	red	Bus collision on Port 1
Err	red	Internal error
Run	green	Ethernet interface ready to work

Set switch S2 to position OFF. The IP address can be adjusted now. In switch position ON, the IP address is blocked to avoid unintended change. The rotary switches and switch S1 are without any function.

IP address adjustment

Type Code

Release date: 2022-12-12 Date of issue: 2022-12-12 Filename: t31168_eng.pdf

Order code

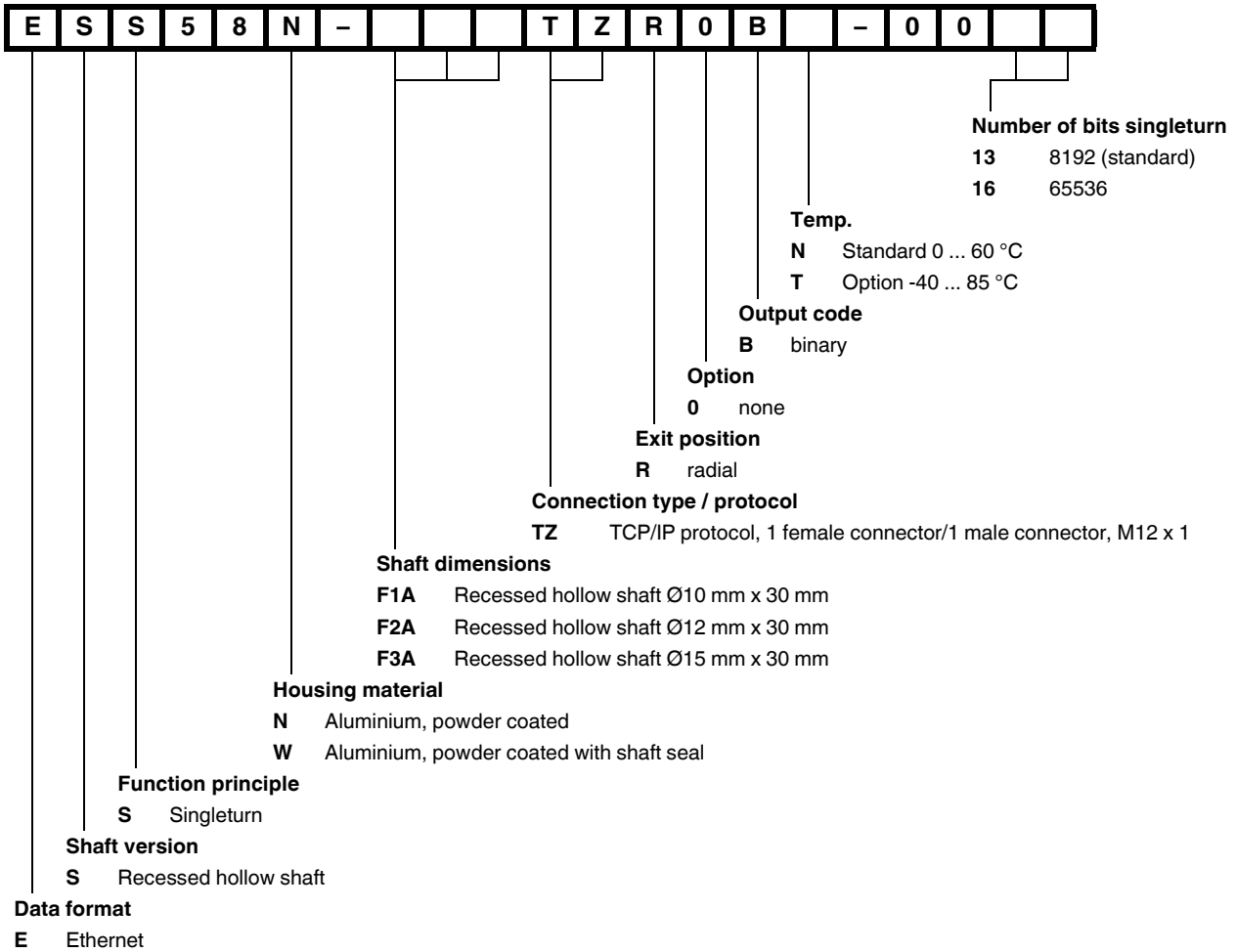

Installation

Anti-interference measures

The use of highly sophisticated microelectronics requires a consistently implemented anti-interference and wiring concept. This becomes all the more important the more compact the constructions are and the higher the demands are on the performance of modern machines.

The following installation instructions and proposals apply for "normal industrial environments". There is no ideal solution for all interfering environments.

When the following measures are applied, the encoder should be in perfect working order:

- Termination of the serial line with a 120 Ω resistor (between Receive/Transmit and Receive/Transmit) at the beginning and end of the serial line (e. g. the control and the last encoder).
- The wiring of the encoder should be laid at a large distance to energy lines which could cause interferences.
- Cable cross-section of the screen at least 4 mm².
- Cable cross-section at least 0,14 mm².
- The wiring of the screen and 0 V should be arranged radially, if and when possible.
- Do not kink or jam the cables.
- Adhere to the minimum bending radius as given in the data sheet and avoid tensile as well as shearing load.

Operating instructions

Every encoder manufactured by Pepperl+Fuchs leaves the factory in a perfect condition. In order to ensure this quality as well as a faultless operation, the following specifications have to be taken into consideration:

- Avoid any impact on the housing and in particular on the encoder shaft as well as the axial and radial overload of the encoder shaft.
- The accuracy and service life of the encoder is guaranteed only, if a suitable coupling is used.
- The operating voltage for the encoder and the follow-up device (e. g. control) has to be switched on and off simultaneously.
- Any wiring work has to be carried out with the system in a dead condition.
- The maximum operating voltages must not be exceeded. The devices have to be operated at extra-low safety voltage.

Release date: 2022-12-12 Date of issue: 2022-12-12 Filename: t31168_eng.pdf

Refer to "General Notes Relating to Pepperl+Fuchs Product Information".

Notes on connecting the electric screening

The immunity to interference of a plant depends on the correct screening. In this field installation faults occur frequently. Often the screen is applied to one side only, and is then soldered to the earthing terminal with a wire, which is a valid procedure in LF engineering. However, in case of EMC the rules of HF engineering apply.

One basic goal in HF engineering is to pass the HF energy to earth at an impedance as low as possible as otherwise energy would discharge into the cable. A low impedance is achieved by a large-surface connection to metal surfaces.

The following instructions have to be observed:

- Apply the screen on both sides to a "common earth" in a large surface, if there is no risk of equipotential currents.
- The screen has to be passed behind the insulation and has to be clamped on a large surface below the tension relief.
- In case of cable connections to screw-type terminals, the tension relief has to be connected to an earthed surface.
- If plugs are used, metallised plugs only should be fitted (such as sub D plugs with metallised housing). Please observe the direct connection of the tension relief to the housing.

Advantage:	metallised connector,
shield	
	clamped with the strain
relief	clamp
Disadvantage:	soldering shield on

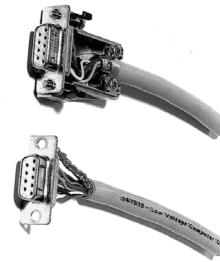

Safety instructions

Please observe the national safety and accident prevention regulations as well as the subsequent safety instructions in these operating instructions when working on encoders.

If failures cannot be remedied, the device has to be shut down and has to be secured against accidental operation.

Repairs may be carried out only by the manufacturer. Entry into and modifications of the device are not permissible.

Tighten the clamping ring only, if a shaft has been fitted in the area of the clamping ring (hollow shaft encoders).

Tighten all screws and plug connectors prior to operating the encoder.

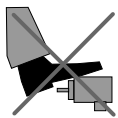

Do not stand on the encoder!

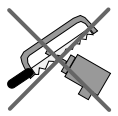

Do not remachine the drive shaft!

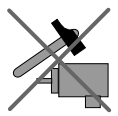

Avoid impact!



Do not remachine the housing!

Release date: 2022-12-12 Date of issue: 2022-12-12 Filename: t31168_eng.pdf