

Incremental rotary encoder

RVI58X-*****1

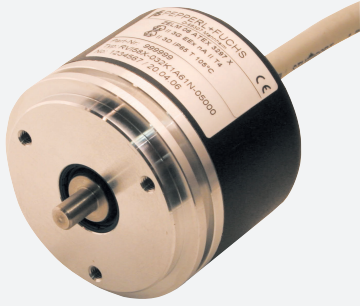

- Industrial standard housing $\varnothing 58$ mm
- ATEX approval
- Up to 5000 ppr
- Servo or clamping flange
- 10 V ... 30 V with short-circuit proof push-pull output



Function

Compatibility says it all for this incremental rotary encoder.

All six output channels are fitted for this incremental rotary encoder. It can thus be used universally in many different applications. Focussing on the designs that are most often required has allowed us to offer rapid availability at an attractive price.

The pulse disk is designed in plastic up to 1500 pulses. Beyond that, glass is used.

This incremental rotary encoder is available either in clamping flange design with a shaft 10 mm in diameter x 20 mm or in servo flange design with a shaft 6 mm in diameter x 10 mm.

The electrical connection is made by a cable.

This incremental encoder is designed for operation in zone 2 and zone 22.

Dimensions

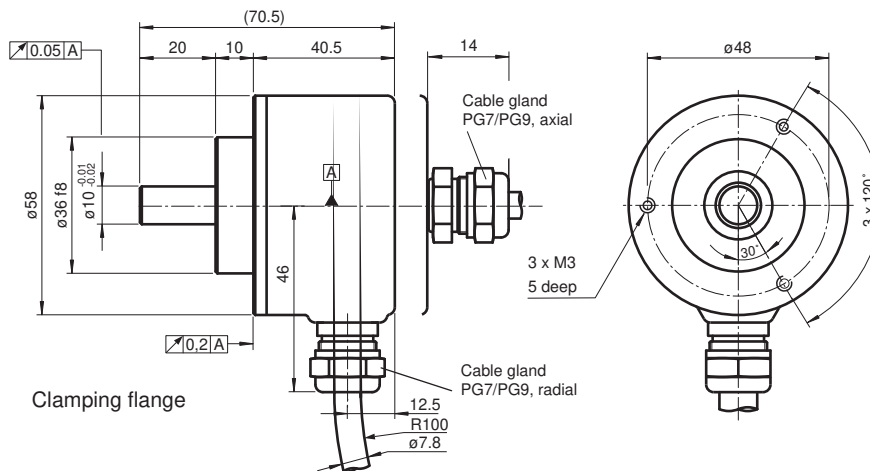

Release date: 2023-03-09 Date of issue: 2023-03-09 Filename: t31551_eng.pdf

Refer to "General Notes Relating to Pepperl+Fuchs Product Information".

Pepperl+Fuchs Group
www.pepperl-fuchs.com

USA: +1 330 486 0001
fa-info@us.pepperl-fuchs.com

Germany: +49 621 776 1111
fa-info@de.pepperl-fuchs.com

Singapore: +65 6779 9091
fa-info@sg.pepperl-fuchs.com

PEPPERL+FUCHS

Dimensions

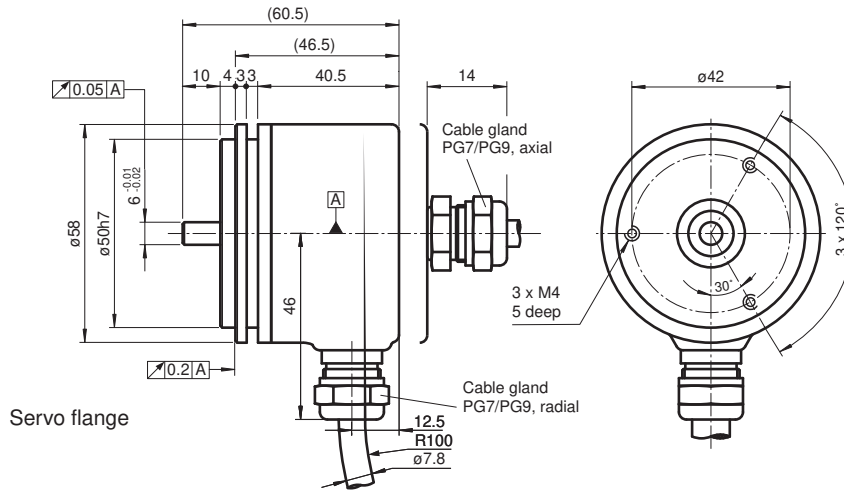

Technical Data

| | |
|---|--|
| General specifications | |
| Detection type | photoelectric sampling |
| Pulse count | max. 5000 |
| Functional safety related parameters | |
| MTTF _d | 140 a |
| Mission Time (T _M) | 20 a |
| L ₁₀ | 70 E+9 at 6000 rpm |
| Diagnostic Coverage (DC) | 0 % |
| Electrical specifications | |
| Operating voltage | U _B 10 ... 30 V DC |
| No-load supply current | I ₀ max. 60 mA |
| Output | |
| Output type | push-pull, incremental |
| Voltage drop | U _d < 3 V |
| Load current | max. per channel 40 mA , short-circuit prtected (not with U _b), reverse polarity protected |
| Output frequency | max. 200 kHz |
| Rise time | 400 ns |
| Connection | |
| Cable | Ø7.8 mm, 6 x 2 x 0.14 mm ² , 1 m |
| Standard conformity | |
| Degree of protection | DIN EN 60529, IP64 |
| Climatic testing | DIN EN 60068-2-3, no moisture condensation |
| Emitted interference | EN 61000-6-4:2007/A1:2011 |
| Noise immunity | EN 61000-6-2:2005 |
| Shock resistance | DIN EN 60068-2-27, 100 g, 3 ms |
| Vibration resistance | DIN EN 60068-2-6, 10 g, 10 ... 2000 Hz |
| Approvals and certificates | |
| UL approval | cULus Listed, General Purpose, Class 2 Power Source |
| Ambient conditions | |
| Operating temperature | |
| Glass disk | -30 ... 70 °C (-22 ... 158 °F) , fixed cable |
| Plastic disk | -30 ... 60 °C (-22 ... 140 °F) , fixed cable |
| Storage temperature | |
| Glass disk | -30 ... 70 °C (-22 ... 158 °F) |
| Plastic disk | -30 ... 70 °C (-22 ... 158 °F) |
| Mechanical specifications | |













Release date: 2023-03-09 Date of issue: 2023-03-09 Filename: t31551_eng.pdf

Refer to "General Notes Relating to Pepperl+Fuchs Product Information".

Technical Data

| | | |
|--|--|---|
| Material | | |
| Housing | | powder coated aluminum |
| Flange | | Aluminum |
| Shaft | | Stainless steel |
| Mass | | approx. 350 g |
| Rotational speed | | max. 6000 min ⁻¹ |
| Moment of inertia | | ≤ 25 gcm ² |
| Starting torque | | ≤ 1.5 Ncm |
| Shaft load | | |
| Axial | | 40 N |
| Radial | | 60 N |
| Data for application in connection with hazardous areas | | |
| ATEX marking | | ⊕ II 3G Ex nA IIB T4 Gc X ⊕ II 3D Ex tc IIIC T105°C Dc X |
| Certificate | | PF 18 CERT 4775 X |
| Directive conformity | | |
| Directive 2014/34/EU | | EN IEC 60079-0:2018 , EN 60079-15:2010 , EN 60079-31:2014 |

Accessories

| | | |
|---|-------------------|-----------------------------------|
|  | 9203 | Angled flange |
|  | 9310-3 | Synchro clamping element |
|  | 9300 | Mounting bracket for servo flange |
|  | KW-10/10 | Helical coupling |
|  | KW-6/10 | Helical coupling |
|  | KW-6/6 | Helical coupling |
|  | KW-6/8 | Helical coupling |
|  | 9401 10*10 | Spring steel coupling |
|  | 9401 10*12 | Spring steel coupling |
|  | 9401 6*10 | Spring steel coupling |
|  | 9401 6*6 | Spring steel coupling |
|  | 9402 6*6 | Spring steel coupling |
|  | 9404 10*10 | Spring disk coupling |



















Release date: 2023-03-09 Date of issue: 2023-03-09 Filename: t31551_eng.pdf

Refer to "General Notes Relating to Pepperl+Fuchs Product Information".

Pepperl+Fuchs Group
www.pepperl-fuchs.comUSA: +1 330 486 0001
fa-info@us.pepperl-fuchs.comGermany: +49 621 776 1111
fa-info@de.pepperl-fuchs.comSingapore: +65 6779 9091
fa-info@sg.pepperl-fuchs.com

PEPPERL+FUCHS

Accessories

| | | |
|---|-------------------|--|
|  | 9404 6*6 | Spring disk coupling |
|  | 9409 10*10 | Bellows coupling |
|  | 9409 6*10 | Bellows coupling |
|  | 9409 6*6 | Bellows coupling |
|  | 9409 6*8 | Bellows coupling |
|  | 9410 10*10 | Precision coupling |
|  | 9410 6*6 | Precision coupling |
|  | 9101, 10 | Measuring wheel for shaft diameter 10 mm |
|  | 9102, 10 | Measuring wheel for shaft diameter 10 mm |
|  | 9103, 10 | Measuring wheel for shaft diameter 10 mm |
|  | 9108, 10 | Measuring wheel for shaft diameter 10 mm |
|  | 9109, 10 | Measuring wheel for shaft diameter 10 mm |
|  | 9110, 10 | Measuring wheel for shaft diameter 10 mm |
|  | 9112, 10 | Measuring wheel for shaft diameter 10 mm |
|  | 9113, 10 | Measuring wheel for shaft diameter 10 mm |
|  | 9108, 6 | Measuring wheel |
|  | 9109, 6 | Measuring wheel for shaft diameter 6 mm |
|  | 9110, 6 | Measuring wheel for shaft diameter 6 mm |
|  | 9113, 6 | Measuring wheel for shaft diameter 6 mm |

Release date: 2023-03-09 Date of issue: 2023-03-09 Filename: t31551_eng.pdf

Refer to "General Notes Relating to Pepperl+Fuchs Product Information".

Pepperl+Fuchs Group
www.pepperl-fuchs.comUSA: +1 330 486 0001
fa-info@us.pepperl-fuchs.comGermany: +49 621 776 1111
fa-info@de.pepperl-fuchs.comSingapore: +65 6779 9091
fa-info@sg.pepperl-fuchs.com **PEPPERL+FUCHS**

Connection

| Signal | Cable Ø7.8 mm, 12-core |
|-----------------------------------|------------------------|
| GND | White |
| U _b | Brown |
| A | Green |
| B | Grey |
| \bar{A} | Yellow |
| \bar{B} | Pink |
| 0 | Blue |
| $\bar{0}$ | Red |
| NC | Grey/Pink |
| U _b Sens ^{*)} | Violet |
| GND Sens ^{*)} | Black |
| Screen | - |

*) only for devices with 5 V supply and RS 422 interface

Operation

Signal outputs

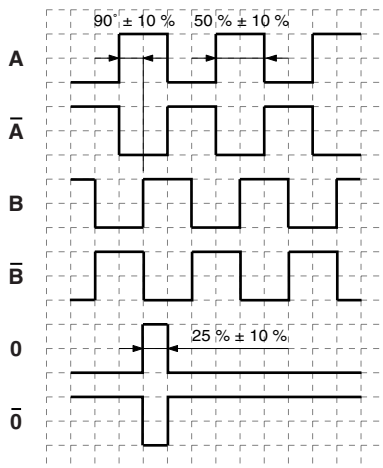

↻ cw - with view onto the shaft

Type Code

Release date: 2023-03-09 Date of issue: 2023-03-09 Filename: t31551_eng.pdf



Pulse count 100, 360, 500, 512,
1000, 1024, 1250, 2048,
2500, 3600, 4096, 5000

Option
N normal

Output switching
1 10 V ... 30 V, push-pull
6 5 V, RS 422
X 10 V ... 30 V, RS 422

Signal output
6 A + B + 0 und \bar{A} + \bar{B} + 0

Exit position
A axial
R radial

Connection type
K1 Cable Ø7,8 mm, 6 x 2 x 0,14 mm², 1 m

Shaft dimension/flange version
011 Shaft Ø10 mm x 20 mm with clamping flange
032 Shaft Ø6 mm x 10 mm with servo flange

Housing material
X design for hazzardous areas

Shaft version
V Solid shaft