

Singleturn absolute encoder

AVS36M-*****

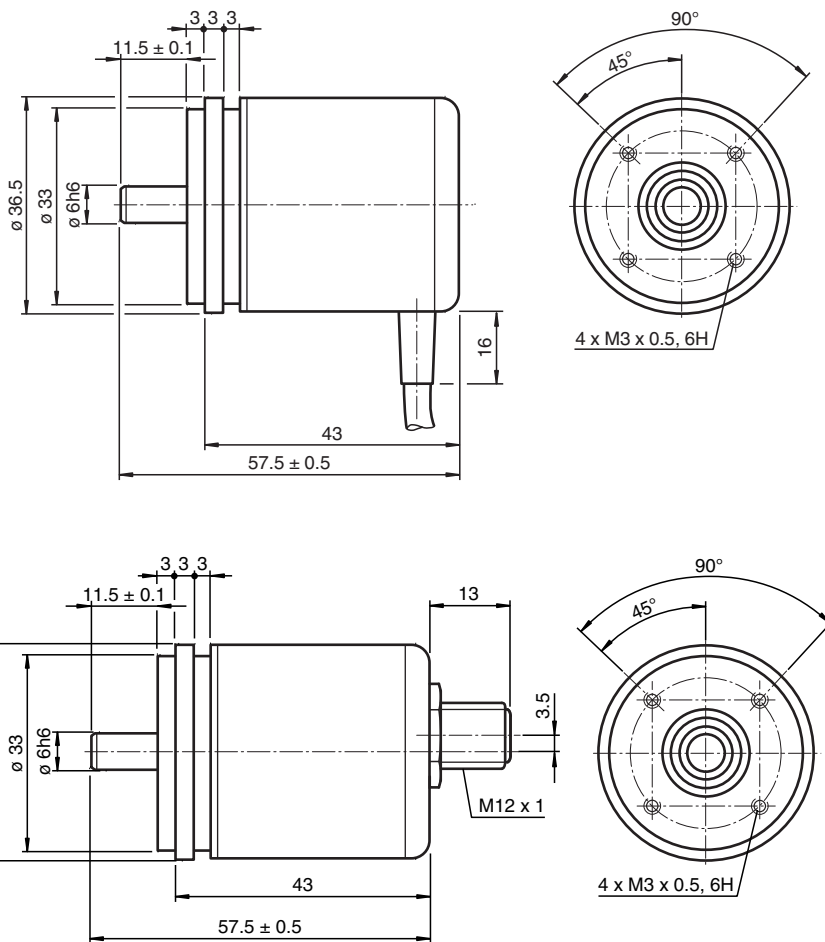

- Very small housing
- High climatic resistance
- Up to 13 Bit singleturn
- SSI interface
- Optically isolated interface
- Surge and reverse polarity protection



Release date: 2022-04-21 Date of issue: 2022-12-12 Filename: t42141_eng.pdf

Technical Data

General specifications

Detection type	magnetic sampling
Device type	Singleturn absolute encoder

Nominal ratings

Linearity error	± 0.36 °
-----------------	----------

Refer to "General Notes Relating to Pepperl+Fuchs Product Information".

Pepperl+Fuchs Group
www.pepperl-fuchs.com

USA: +1 330 486 0001
fa-info@us.pepperl-fuchs.com

Germany: +49 621 776 1111
fa-info@de.pepperl-fuchs.com

Singapore: +65 6779 9091
fa-info@sg.pepperl-fuchs.com



Technical Data





Electrical specifications		
Operating voltage	U_B	4.5 ... 30 V DC
Power consumption	P_0	approx. 2 W
Output code		Gray code, binary code
Code course (counting direction)		adjustable
Interface		
Interface type		SSI
Resolution		
Single turn		up to 13 Bit (hysteresis: 0.1 °)
Overall resolution		up to 13 Bit
Transfer rate		0.1 ... 2 MBit/s
Cycle time		< 600 µs
Standard conformity		RS 422
Input 1		
Input type		Selection of counting direction (cw/ccw)
Signal voltage		
High		4.5 V ... U_B (cw descending)
Low		0 ... 2 V or unconnected (cw ascending)
Input current		< 6 mA
Switch-on delay		< 1.1 s
Input 2		
Input type		zero-set (PRESET 1) with falling edge
Signal voltage		
High		4.5 V ... U_B
Low		0 ... 2 V
Input current		< 6 mA
Signal duration		min. 1.1 s
Connection		
Connector		M12 connector, 8-pin
Cable		Ø6 mm, 4 x 2 x 0.14 mm ² , 1 m
Standard conformity		
Degree of protection		acc. DIN EN 60529
Connection side		cable models: IP54 connector models: IP65
Shaft side		IP65
Climatic testing		DIN EN 60068-2-3, no moisture condensation
Emitted interference		EN 61000-6-4:2007
Noise immunity		EN 61000-6-2:2005
Shock resistance		DIN EN 60068-2-27, 100 g, 6 ms
Vibration resistance		DIN EN 60068-2-6, 10 g, 10 ... 1000 Hz
Ambient conditions		
Operating temperature		cable, flexing: -5 ... 70 °C (-23 ... 158 °F), cable, fixed: -30 ... 70 °C (-22 ... 158 °F) connector models: -30 ... 85 °C (-22 ... 185 °F)
Storage temperature		cable models: -30 ... 70 °C (-22 ... 158 °F) connector models: -30 ... 85 °C (-22 ... 185 °F)
Relative humidity		98 % , no moisture condensation
Mechanical specifications		
Material		
Housing		nickel-plated steel
Flange		aluminum
Shaft		Stainless steel
Mass		approx. 150 g , with cable
Rotational speed		max. 12000 min ⁻¹

Release date: 2022-04-21 Date of issue: 2022-12-12 Filename: t42141_eng.pdf

Technical Data

Moment of inertia	30 gcm ²
Starting torque	< 3 Ncm
Shaft load	
Axial	20 N
Radial	40 N

Accessories

	V19-G-ABG-PG9	Female connector M12 straight A-coded 8-pin, for cable diameter 5 - 8 mm, shielded, field-attachable
	9108, 6	Measuring wheel
	9109, 6	Measuring wheel for shaft diameter 6 mm
	9110, 6	Measuring wheel for shaft diameter 6 mm
	9113, 6	Measuring wheel for shaft diameter 6 mm

Release date: 2022-04-21 Date of issue: 2022-12-12 Filename: t42141_eng.pdf

Refer to "General Notes Relating to Pepperl+Fuchs Product Information".

Pepperl+Fuchs Group
www.pepperl-fuchs.com

USA: +1 330 486 0001
fa-info@us.pepperl-fuchs.com

Germany: +49 621 776 1111
fa-info@de.pepperl-fuchs.com

Singapore: +65 6779 9091
fa-info@sg.pepperl-fuchs.com

Function

This singleturn absolute encoder transmits a position value corresponding to the shaft setting via the SSI interface (Synchronous Serial Interface).

The AVS36M series are encoders with internal magnetic sampling.

The control module sends a start sequence to the absolute encoder to obtain the position data. The rotary encoder then sends the position data synchronous to the cycles of the control module. It is possible to select the counting direction with the function input.

Electrical connection

Signal	Wire end	Connector
GND (encoder)	White	1
U _b (encoder)	Brown	2
Clock (+)	Green	3
Clock (-)	Yellow	4
Data (+)	Grey	5
Data (-)	Pink	6
Preset	Black or Blue	7
Counting direction	Red	8
Shielding	Shielding	Housing
Pinout	-	

Interface

Description

The Synchronous Serial Interface was specially developed for transferring the output data of an absolute encoder to a control device. The control module sends a clock bundle and the absolute encoder responds with the position value.

Thus only 4 lines are required for the clock and data, no matter what the resolution of the rotary encoder is. The RS 422 interface is optically isolated from the power supply.

SSI signal course Standard

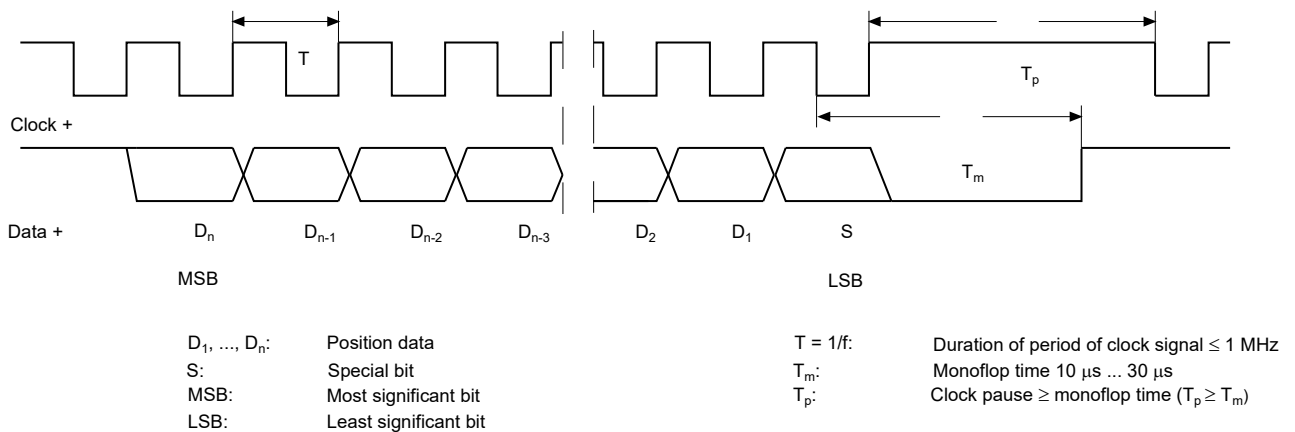

SSI output format Standard

- At idle status signal lines "Data +" and "Clock +" are at high level (5 V).
- The first time the clock signal switches from high to low, the data transfer in which the current information (position data (D_n) and special bit (S)) is stored in the encoder is introduced.
- The highest order bit (MSB) is applied to the serial data output of the encoder with the first rising pulse edge.
- The next successive lower order bit is transferred with each following rising pulse edge.
- After the lowest order bit (LSB) has been transferred the data line switches to low until the monoflop time T_m has expired.
- No subsequent data transfer can be started until the data line switches to high again or the time for the clock pause T_p has expired.
- After the clock sequence is complete, the monoflop time T_m is triggered with the last falling pulse edge.
- The monoflop time T_m determines the lowest transmission frequency.

SSI output format ring slide operation (multiple transmission)

Release date: 2022-04-21 Date of issue: 2022-12-12 Filename: t42141_eng.pdf

- In ring slide operation, multiple transmission of the same data word over the SSI interface makes it possible to offer the possibility of detecting transmission errors.
- In multiple transmission, 25 bits are transferred per data word in standard format.
- If the clock change is not interrupted after the last falling pulse edge, ring slide operation automatically becomes active. This means that the information that was stored at the time of the first clock change is generated again.
- After the first transmission, the 26th pulse controls data repetition. If the 26th pulse follows after an amount of time greater than the monoflop time T_m , a new current data word will be transmitted with the following pulses.



If the pulse line is exchanged, the data word is generated offset.
Ring slide operation is possible up to max. 13 bits.

Block diagram

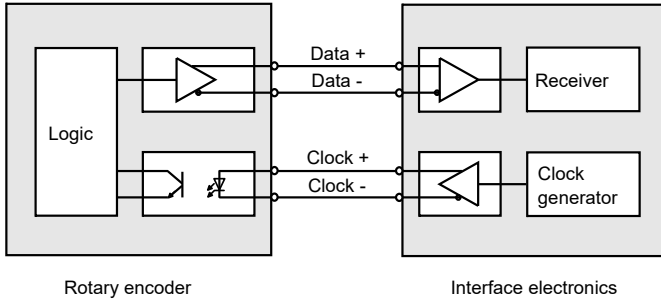

Line length

Line length in m	Baudrate in kHz
< 50	< 400
< 100	< 300
< 200	< 200
< 400	< 100

Order code

A V S 3 6 M - 0 3 S **0** **N - 0 0**

Number of bits singleturn
 12 4096 (standard)
 13 8192 (max.)

Temperature
N Normal

Output code
B Binary
G Gray

Option
 0 cw/ccw and preset

Exit position
A Axial
R Radial (only cable version)

Connection type
K1 Cable Ø6 mm, 4 x 2 x 0.14 mm², 1 m
BE Connector, M12 x 1, 8 pin

Shaft dimension/flange version
03S Shaft Ø6 mm x 11.5 mm with servo flange

Sampling principle
M magnetic

Principle of operation
S Singleturn

Shaft version
V Solid shaft

Data format
A SSI (Synchronous Serial Interface)

Release date: 2022-04-21 Date of issue: 2022-12-12 Filename: t42141_eng.pdf

Installation

Anti-interference measures

The use of highly sophisticated microelectronics requires a consistently implemented anti-interference and wiring concept. This becomes all the more important the more compact the constructions are and the higher the demands are on the performance of modern machines.

The following installation instructions and proposals apply for "normal industrial environments". There is no ideal solution for all interfering environments.

When the following measures are applied, the encoder should be in perfect working order:

- Termination of the serial line with a 120 Ω resistor (between Receive/Transmit and Receive/Transmit) at the beginning and end of the serial line (e. g. the control and the last encoder).
- The wiring of the encoder should be laid at a large distance to energy lines which could cause interferences.
- Cable cross-section of the screen at least 4 mm².
- Cable cross-section at least 0,14 mm².
- The wiring of the screen and 0 V should be arranged radially, if and when possible.
- Do not kink or jam the cables.
- Adhere to the minimum bending radius as given in the data sheet and avoid tensile as well as shearing load.

Operating instructions

Every encoder manufactured by Pepperl+Fuchs leaves the factory in a perfect condition. In order to ensure this quality as well as a faultless operation, the following specifications have to be taken into consideration:

- Avoid any impact on the housing and in particular on the encoder shaft as well as the axial and radial overload of the encoder shaft.
- The accuracy and service life of the encoder is guaranteed only, if a suitable coupling is used.
- The operating voltage for the encoder and the follow-up device (e. g. control) has to be switched on and off simultaneously.
- Any wiring work has to be carried out with the system in a dead condition.
- The maximum operating voltages must not be exceeded. The devices have to be operated at extra-low safety voltage.

Notes on connecting the electric screening

The immunity to interference of a plant depends on the correct screening. In this field installation faults occur frequently. Often the screen is applied to one side only, and is then soldered to the earthing terminal with a wire, which is a valid procedure in LF engineering. However, in case of EMC the rules of HF engineering apply.

One basic goal in HF engineering is to pass the HF energy to earth at an impedance as low as possible as otherwise energy would discharge into the cable. A low impedance is achieved by a large-surface connection to metal surfaces.

The following instructions have to be observed:

- Apply the screen on both sides to a "common earth" in a large surface, if there is no risk of equipotential currents.
- The screen has to be passed behind the insulation and has to be clamped on a large surface below the tension relief.
- In case of cable connections to screw-type terminals, the tension relief has to be connected to an earthed surface.
- If plugs are used, metallised plugs only should be fitted (such as sub D plugs with metallised housing). Please observe the direct connection of the tension relief to the housing.

Advantage:	metallised connector,
shield	clamped with the strain
relief	clamp
Disadvantage:	soldering shield on

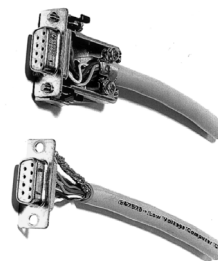

Safety instructions

Please observe the national safety and accident prevention regulations as well as the subsequent safety instructions in these operating instructions when working on encoders.

If failures cannot be remedied, the device has to be shut down and has to be secured against accidental operation.

Repairs may be carried out only by the manufacturer. Entry into and modifications of the device are not permissible.

Tighten the clamping ring only, if a shaft has been fitted in the area of the clamping ring (hollow shaft encoders).

Tighten all screws and plug connectors prior to operating the encoder.

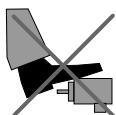

Do not stand on the encoder!

Release date: 2022-04-21 Date of issue: 2022-12-12 Filename: t42141_eng.pdf

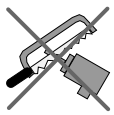

Do not remachine the drive shaft!

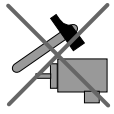

Avoid impact!



Do not remachine the housing!