

Temperature head transmitter HUT



- 2-, 3- and 4-wire technology, 4 mA ... 20 mA analog output
- High accuracy in total ambient temperature range
- Universally PC programmable for various signals
- Fault signal on sensor break or short circuit, presettable to NAMUR NE43
- Online configuration during measurement using SETUP connector
- Customer specific linearization
- EMC acc. to NAMUR NE 21



Function

The temperature head transmitter linearises the signal from resistance sensors (RTD) and provides a 4 mA ... 20 mA current output. The input circuit is galvanically isolated from the output circuit.

The device is intrinsically safe in accordance with EEx ia IIC. The temperature head transmitter may be configured in situ with a programming socket to operate over the desired temperature range with a Pt100.

Setting up of the transmitter is done using the TXU10L configuration kit.

The transmitter is polarity protected and will not be damaged by connecting the power supply with the wrong polarity. The maximum load in the output loop depends on the supply voltage.

Connection

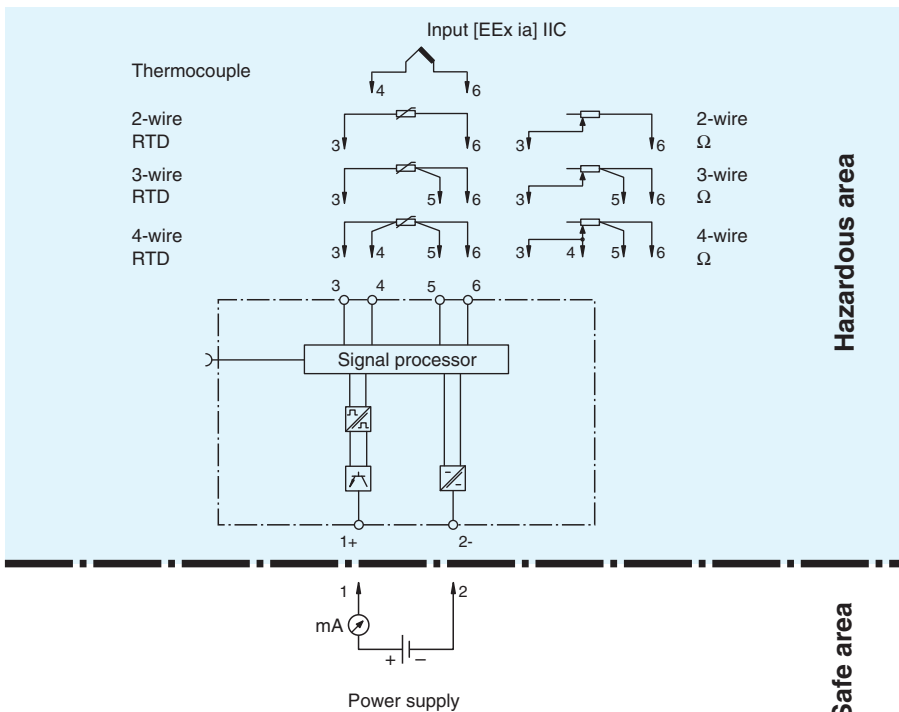

Release date: 2020-10-05 Date of issue: 2020-10-05 Filename: t42713_eng.pdf

Refer to "General Notes Relating to Pepperl+Fuchs Product Information".

Pepperl+Fuchs Group
www.pepperl-fuchs.com

USA: +1 330 486 0002
pa-info@us.pepperl-fuchs.com

Germany: +49 621 776 2222
pa-info@de.pepperl-fuchs.com

Singapore: +65 6779 9091
pa-info@sg.pepperl-fuchs.com

PF PEPPERL+FUCHS

Dimensions

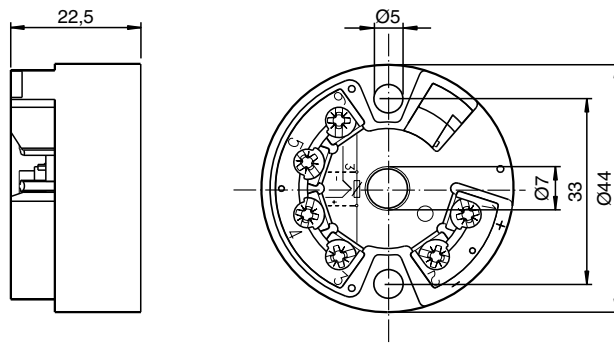

Technical Data

Supply		
Connection		terminals 1, 2
Rated voltage	U_r	8 ... 35 V DC 8 ... 30 V DC for hazardous area
Input		
Sensor types		resistance thermometer (RTD): - Pt100, Pt500, Pt1000 acc. to IEC 751 and Ni100, Ni500, Ni1000 acc. to DIN 43760 resistance transmitter (Ω) thermocouple (TC): - B (PtRh30-PtRh6), C (W5Re-W26Re), D (W3Re-W25Re), E (NiCr-CuNi), J (Fe-CuNi), K (NiCr-Ni), L (Fe-CuNi), N (NiCrSi-NiSi), R (PtRh13-Pt), S (PtRh10-Pt), T (Cu-CuNi), U (Cu-CuNi), MoRe5-MoRe41 acc. to IEC 584, part 1 voltage transmitter (mV)
Connection		resistance thermometer (RTD): - 2-wire connection: terminals 3, 6 - 3-wire connection: terminals 3, 5, 6 - 4-wire connection: terminals 3, 4, 5, 6 resistance transmitter (Ω): - 2-wire connection: terminals 3, 6 - 3-wire connection: terminals 3, 5, 6 - 4-wire connection: terminals 3, 4, 5, 6 thermocouple (TC): terminals 4, 6
Cold junction compensation		internal (Pt100) or external (0 ... 80 °C (273 ... 353 K)), accuracy ± 1 K
Lead resistance		resistance thermometer (RTD): max. 11 Ω per line
Current		resistance thermometer (RTD): sensor current ≤ 0.6 mA thermocouple (TC): sensor current 30 mA
Output		
Connection		terminals 1, 2
Current limit		≤ 25 mA
Load		$(V_s - 8)/0.025$ A
Switch-on delay	t_{on}	4 s, during power up $I_a = 3.8$ mA
Output signal		4 ... 20 mA, 20 ... 4 mA temperature linear, resistance linear, voltage linear
Residual ripple		$U_{pp} \leq 5$ V at $U_b \geq 13$ V, $f_{max} = 1$ kHz
Response time		1 s
Self current consumption		max. 3.5 mA
Signal on alarm		measuring range undercut: linear drop to 3.8 mA exceeding measuring range: linear rise to 20.5 mA sensor breakage, sensor short circuit: ≤ 3.6 mA oder ≥ 21.0 mA can be set up
Galvanic isolation		
Input/Output		safe galvanic isolation acc. to EN 50020, 3.75 kV AC
Measurement accuracy		
Reference operating conditions		calibration temperature 23 °C (296 K) ± 5 K

Release date: 2020-10-05 Date of issue: 2020-10-05 Filename: t42713_eng.pdf

Technical Data

Maximum measured error	resistance thermometer (RTD): 0.2 ... 0.5 K or 0.08 ... 0.2 % resistance transmitter (Ω): $\pm 0.1 ... 1.5 \Omega$ or 0.08 ... 0.12 % thermocouple (TC): typ. 0.5 ... 2.0 K or 0.08 % voltage transmitter: $\pm 20 \mu\text{V}$ or 0.08 %
Operating conditions	
Ambient conditions	
Ambient temperature	-40 ... 85 °C (-40 ... 185 °F) , for hazardous area see certificate
Storage temperature	-40 ... 100 °C (-40 ... 212 °F)
Vibration resistance	4 g/2 ... 150 Hz
Relative humidity	moisture condensation allowable
Mechanical specifications	
Degree of protection	IP00/IP66 installed
Connection	Terminals for wires max. 1.75 mm ² , undetachable screws
Material	housing: PC potting: PUR
Mass	approx. 40 g
Dimensions	Ø44 x 22,5 mm (1.7 x 0.9 inch)
Mechanical construction	
Construction type	connection head acc. to DIN 43729 form B, field housing
Indication and operation	
Configuration	via PC operating software, configuration set TXU 10L interface: PC interface connection cable TTL-/RS 232 with plug
Certificates and approvals	
Explosion-hazardous area	ZELM 07 ATEX 0352 X , for additional certificates see www.pepperl-fuchs.com
Type of protection	Ⓜ II 1G Ex ia IIC T6/T5/T4
General information	
Directive conformity	
Directive 2004/108/EC (EMC)	emitted interference and noise immunity to EN 61326-1:2006 and EN 61326-2-3:2006
Directive 94/9/EC (ATEX)	EN 60079-0:2006, EN 60079-11:2007, EN 60079-26:2007
Conformity	
Electromagnetic compatibility	NE 21
Degree of protection	EN 60529
Climate class	EN 60654, class C
Vibration resistance	EN 60068-2-6
Supplementary documentation	technical information T10700 operating instructions KA1410 safety information SI0850 (ZELM 07 ATEX 0352 X)
Supplementary information	EC-Type Examination Certificate, Statement of Conformity, Declaration of Conformity, Attestation of Conformity and instructions have to be observed where applicable. For information see www.pepperl-fuchs.com .

Additional Information

Installation instructions

- When used with a RTD, the transmitter may be configured to provide 3-wire connection.
- The programming via PC must be done in safe area and must not be done in the hazardous area.
- Adjustment/calibration: For the configuration, the configuration set TXU10L is required and is executed by means of a PC via adapter to the programming socket.

Accessories

TXU10L, configuration set consisting of interface cable, software and system manual.
Necessary for parameterisation without transmitter power supply.

Type Code



Certificate

- s**
- NA** version for non-hazardous areas
- EX** e II 1G Ex ia II C T6/T5/T4
- FS** FM, IS, Cl. I, Div. 1 + 2, Gr. A, B, C, D
- CU** FM + CSA, IS, NI, Cl. I, Div. 1 + 2, Gr. A, B, C, D
- CS** CSA, IS, NI, Cl. I, Div. 1 + 2, Gr. A, B, C, D

Configuration

- A** factory default setting (Pt100, 3-wire, 0 °C ... 100 °C)
- B** customer specific configuration of measuring range

Sensor type

- 1** type Pt100, -200 °C ... 850 °C, min. span 10 K
- 2** type Pt100 GOST, -200 °C ... 850 °C, min. span 10 K
- 3** type K, -200 °C ... 1372 °C, min. span 50 K

Connection

- 1** thermocouple (TC)
- 2** RTD, 2-wire
- 3** RTD, 3-wire
- 4** RTD, 4-wire

Release date: 2020-10-05 Date of issue: 2020-10-05 Filename: t42713_eng.pdf